

# CONTENTS

	CODING GUIDE . . . . .	2
	DISASSEMBLY PROCEDURE . . . . .	3
	SPECIFICATIONS . . . . .	4
	PANEL LAYOUT . . . . .	5
<b>SK</b>	Circuit Diagram . . . . .	6
<b>SK</b>	Circuit Board & Wiring . . . . .	7
<b>PA</b>	Circuit Diagram . . . . .	8
<b>PA</b>	Circuit Board & Wiring . . . . .	9
<b>PB</b>	Circuit Diagram . . . . .	10
<b>PB</b>	Circuit Board & Wiring . . . . .	11
<b>VCO</b>	Circuit Diagram . . . . .	12
<b>VCO</b>	Circuit Board & Wiring . . . . .	13
<b>FA</b>	Circuit Diagram . . . . .	14
<b>FA</b>	Circuit Board & Wiring . . . . .	15
<b>MOD</b>	Circuit Diagram . . . . .	16
<b>MOD</b>	Circuit Board & Wiring . . . . .	17
<b>PGM</b>	Circuit Diagram . . . . .	18
<b>PGM</b>	Circuit Board & Wiring . . . . .	19
<b>DM</b>	Circuit Diagram . . . . .	20
<b>DM</b>	Circuit Board & Wiring . . . . .	21
<b>PL</b>	Circuit Diagram . . . . .	22
<b>PL</b>	Circuit Board & Wiring . . . . .	23
<b>JK1, JK2</b>	Circuit Diagram . . . . .	24
<b>JK1, JK2</b>	Circuit Board & Wiring . . . . .	25
<b>MK, BL</b>	Circuit Diagram . . . . .	26
<b>BL</b>	Circuit Board & Wiring . . . . .	27
<b>DC</b>	Circuit Diagram . . . . .	28
<b>DC</b>	Circuit Board & Wiring . . . . .	29
	ELECTRICAL CHECKS & ADJUSTMENTS . . . . .	30
	PARTS LIST . . . . .	55

# CODING GUIDE

## 1 Wiring Notation

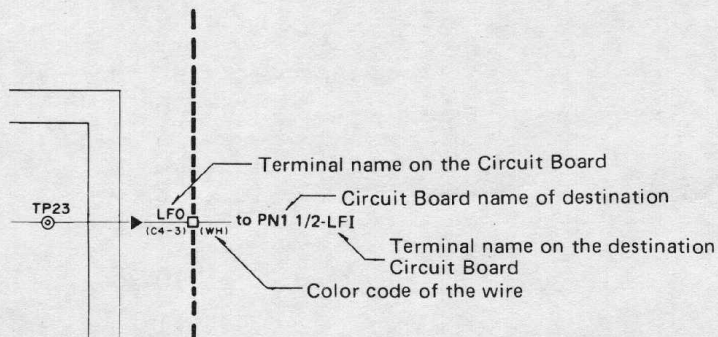

Note: Types of wire

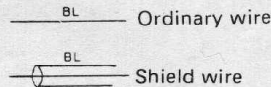

## 2 Symbol Description

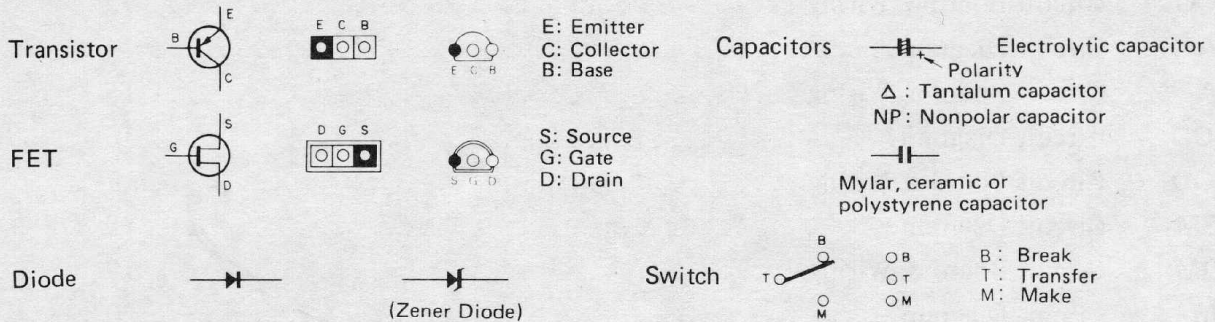

## 3 Abbreviations of Wire Color Codes

BLACK (クロ).....BL	BROWN (チャ).....BR	RED (アカ).....RE
ORANGE (タイ).....OR	YELLOW (キイ).....YE	GREEN (ミト).....GR
BLUE (アオ).....BE	VIOLET (ムラ).....VI	GRAY (ハイ).....GY
WHITE (シロ).....WH	GRASS GREEN (クサ).....GG	SKY BLUE (ソラ).....SB
PINK (モモ).....PK	TRANSPARENT (トウメイ).....TR	

## 4 Relation of Color Coding and Notes

C	C≠	D	D≠	E	F	F≠	G	G≠	A	A≠	B
BR	RE	OR	YE	GR	BE	VI	GY	WH	GG	SB	PK
(チャ)	(アカ)	(タイ)	(キイ)	(ミト)	(アオ)	(ムラ)	(ハイ)	(シロ)	(クサ)	(ソラ)	(モモ)

## 5 Logic Symbols

	MIL	YAMAHA
NOT		
NOR		
NAND		

Exclusive OR (排他的論理和)

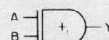

Truth Table

A	B	Y
L	L	L
H	L	H
L	H	H
H	H	L

NOT (Inverter)



Truth Table

A	Y
L	H
H	L

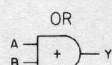

Truth Table

A	B	Y
L	L	L
H	L	H
L	H	H
H	H	H

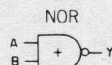

Truth Table

A	B	Y
L	L	H
H	L	L
L	H	L
H	H	L

AND



Truth Table

A	B	Y
L	L	L
H	L	L
L	H	L
H	H	H

NAND



Truth Table

A	B	Y
L	L	H
H	L	H
L	H	H
H	H	L

## DISASSEMBLY PROCEDURE

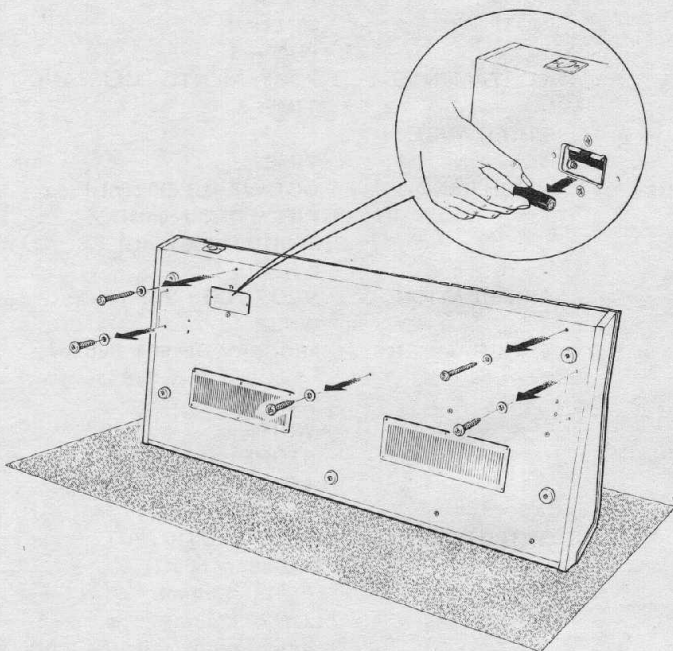

### Opening panel and keyboard

- Put the body on a seat of cloth so that the rear panel should not be damaged. Remove screws of the bottom plate.

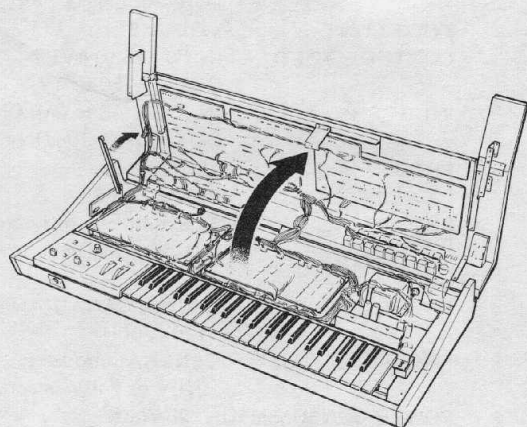

- Uplift the arm, turn it and fix it with the stopper on the left side.

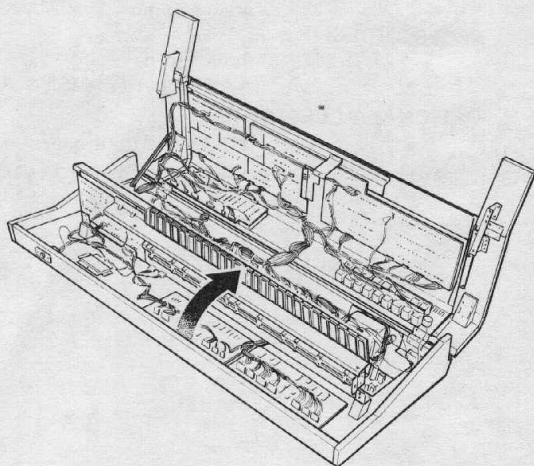

- You can rotate the keyboard, holding the clapper.

# SPECIFICATIONS

**KEYBOARD** . . . . . 37 keys, c1 through c4 (3 octaves)

**CONTROLS**

VCO 1, VCO 2 . . . . . PITCH: -500 to +700 cents  
 FEET: 64', 32', 16', 8', 4', 2'  
 WAVE:  $\wedge$ ,  $\nabla$ ,  $\square$   
 MODULATION FUNCTION:  
 $\sim$ ,  $\nabla$ ,  $\vee$ ,  $\square$ , S/H, GL+, GL-

MIXER . . . . . VCO 1  
 VCO 2  
 NOISE

VCF . . . . . CUT OFF FREQ.  
 RESONANCE: Q= 0.5 to 10  
 HP/BP/LP  
 HP: 12dB/oct.  
 BP:  $\pm$ 6dB/oct.  
 LP: -12dB/oct.

MODULATION FUNCTION:  
 $\sim$ ,  $\nabla$ ,  $\vee$ ,  $\square$ , S/H  
 MODULATION DEPTH  
 EG DEPTH

VCA . . . . .  $\sim$  1  
 MODULATION FUNCTION:  
 $\sim$ ,  $\nabla$ ,  $\vee$ ,  $\square$   
 MODULATION DEPTH  
 INITIAL LEVEL

EG-VCF . . . . .  $\sim$  /  $\vee$   
 NORMAL / TIME x 5  
 ATTACK TIME: 0.001 to 1 sec.  
 (at "NORMAL" setting)  
 DECAY TIME: 0.01 to 10 sec.  
 (ditto)  
 SUSTAIN LEVEL  
 RELEASE TIME: 0.01 to 10 sec.  
 (ditto)

EG-VCA . . . . . NORMAL / TIME x 5  
 ATTACK TIME: 0.001 to 1 sec.  
 (at "NORMAL" setting)  
 DECAY TIME: 0.01 to 10 sec.  
 (ditto)  
 SUSTAIN LEVEL  
 RELEASE TIME: 0.01 to 10 sec.  
 (ditto)

LFO . . . . . TRIGGER: REPEAT / OFF  
 SPEED: 0.1 to 100Hz

GLIDE . . . . . TIME: 0.015 to 15 sec.

OUTPUT . . . . . VOLUME  
 PHONES  
 PORTAMENTO . . . . . PORTAMENTO / GLISSANDO  
 TIME

BRILLIANCE  
 SUSTAIN . . . . . TIME  
 PITCH BEND . . . . . OCTAVE ( $\pm$ 1200 cents)  
 FIFTH ( $\pm$ 700 cents)  
 THIRD ( $\pm$ 400 cents)  
 WHEEL

MODULATION . . . . . VCO / VCO + VCF / VCF  
 WHEEL

PROGRAMMER . . . . . PROGRAM SELECT Buttons  
 1, 2, 3, 4, 5, 6, 7, 8  
 PANEL  
 WRITE  
 STORE  
 LOAD

**JACKS**

OUTPUT . . . . . BALANCED OUTPUT  
 (-16dBm / 600 $\Omega$ )  
 HIGH (-13dBm)  
 LOW (-32dBm)  
 During output of saw-tooth wave  
 ( $\nabla$ ) at basic setting.

FOOT SW. . . . . SUSTAIN  
 PORTAMENTO

FOOT CONT. . . . . VOLUME

CONTROL VOLT . . . . . IN (0.125 to 4V)  
 OUT (0.125 to 4V)

TRIGGER . . . . . IN (OFF: 15 to 3V, ON: 0 to -10V)  
 OUT: (OFF: 3V, ON: -7V)

PROGRAM . . . . . TO TAPE  
 FROM TAPE

PHONES . . . . . 24.5 millivolts rms nominal  
 (8 $\Omega$  or higher impedance)

**OTHERS**

POWER SOURCE. . . . . U.S. and CANADIAN models:  
 120V, 60Hz  
 GENERAL model:  
 220V or 240V selectable, 50/60Hz

POWER CONSUMPTION: 28 Watts

DIMENSIONS . . . . . 849 x 177 x 455.5mm  
 (W x H x D)  
 (33-3/8 x 7 x 17-7/8")

WEIGHT . . . . . 16kg (35.3 lbs.)

FINISH . . . . . Semi-gloss black panels, rosewood-grain cabinet

**ACCESSORIES:**

Power cord  
 Alkaline batteries (Size: AA) x 2

**OPTIONAL ACCESSORIES:**

FC-3 Foot Controller  
 FC-4 Foot Switch Pedal

Specifications subject to change without notice.

# PANEL LAYOUT

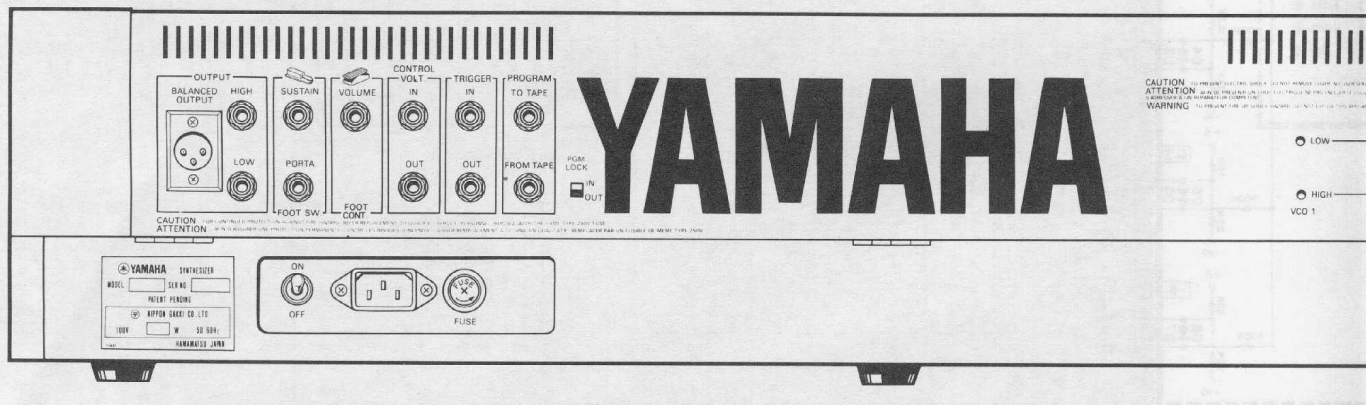
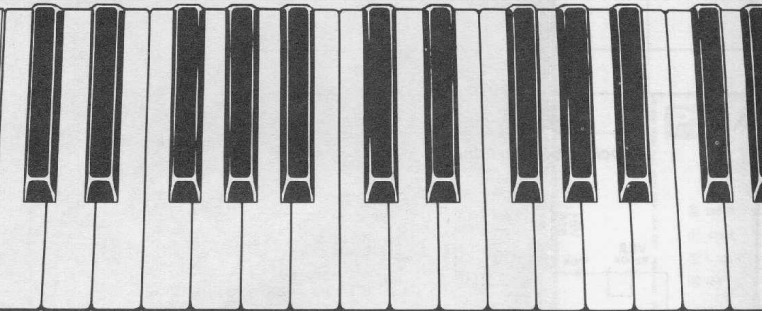
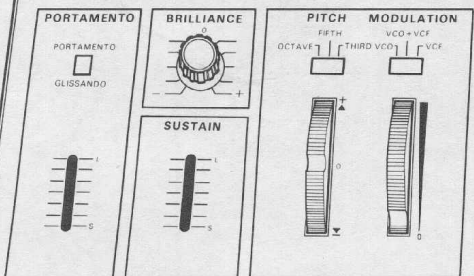
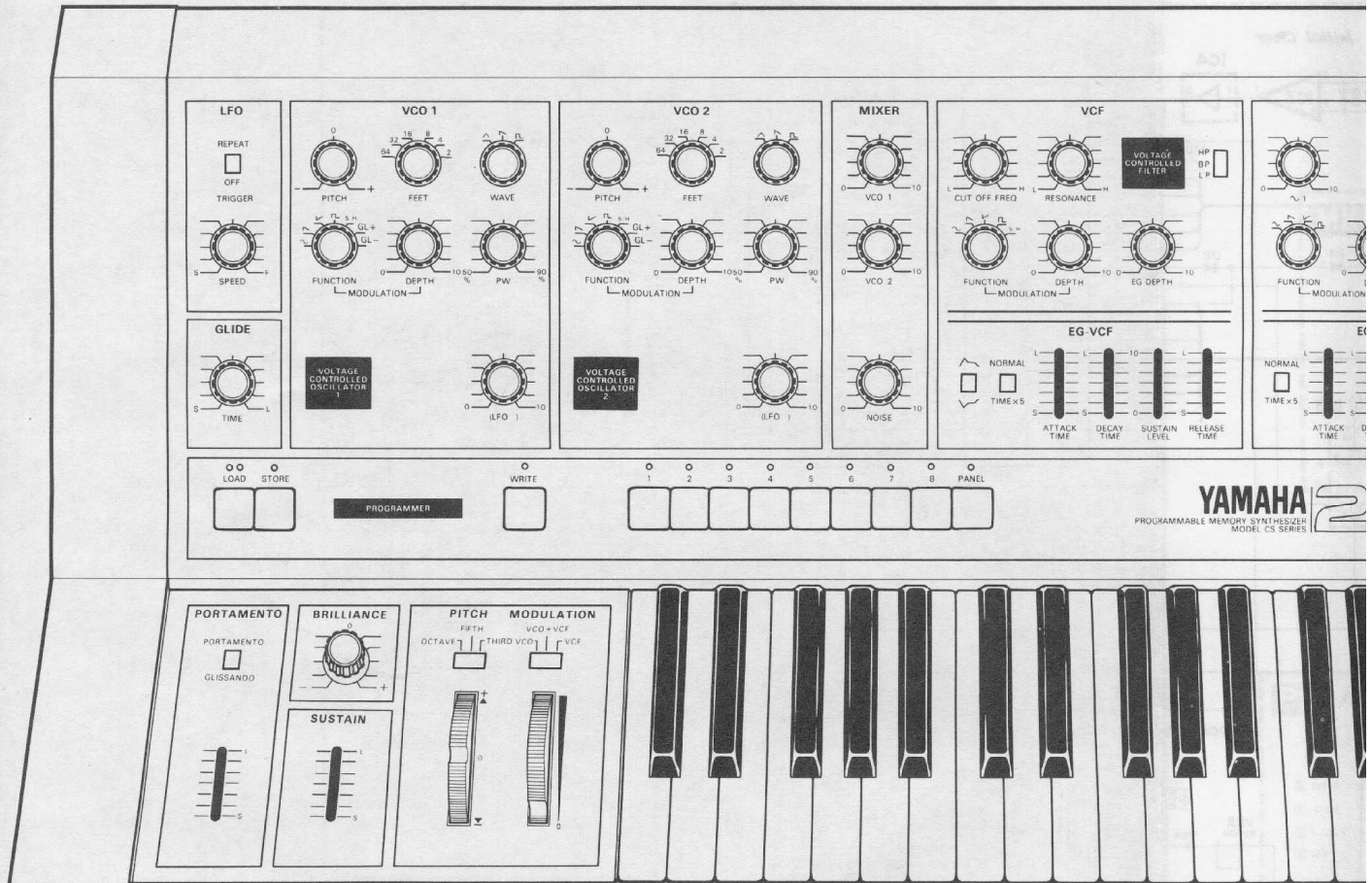

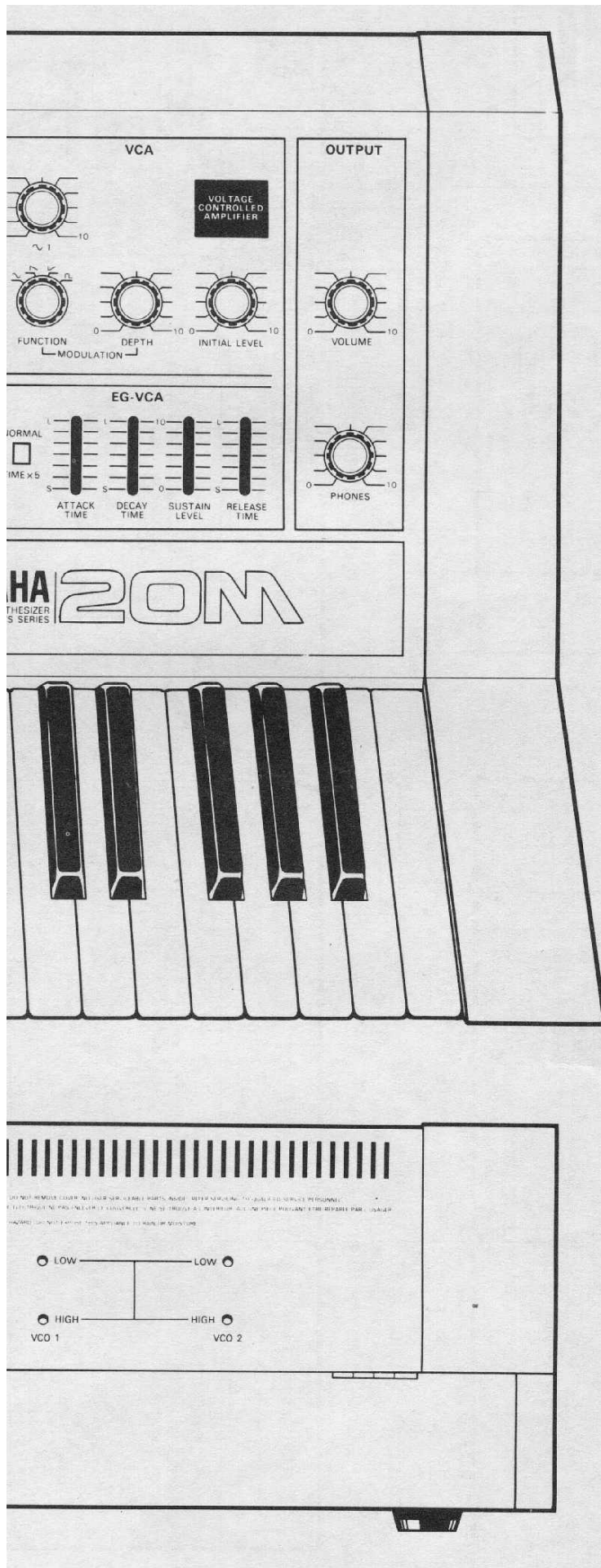

**KEYBOARD (C3-C6)**

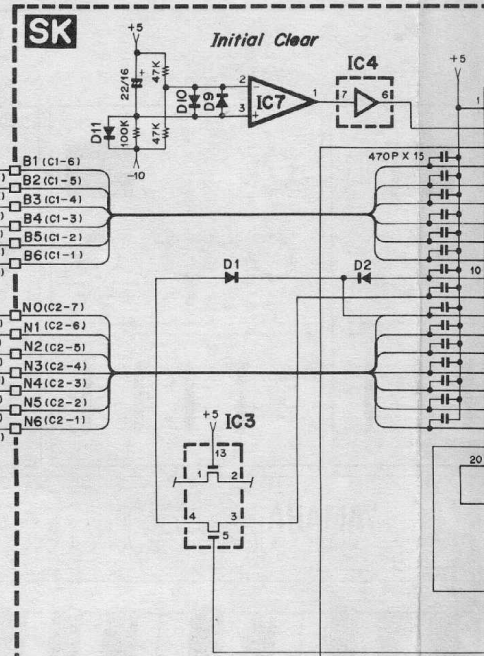
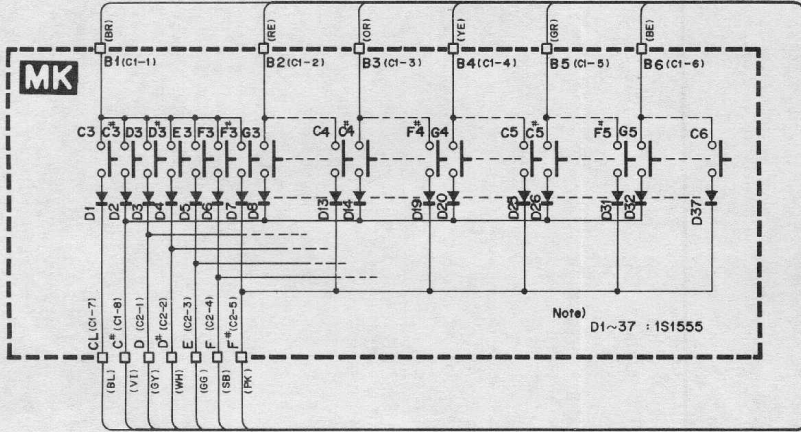
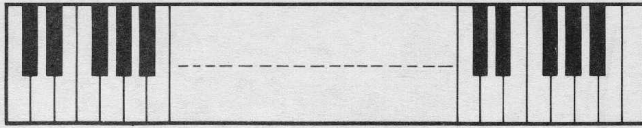

**PL 1/4**

**Key Volt Generator**

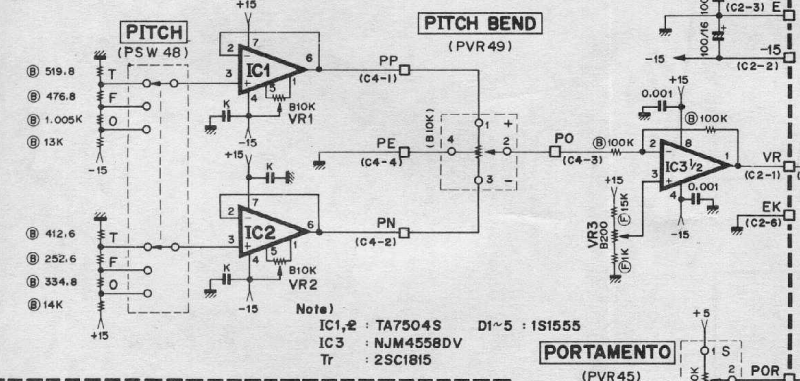

**JK2 1/5**



**PORTAMENTO**

(PVR 45)

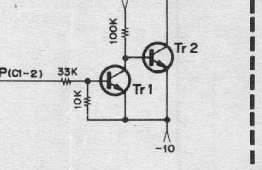

**GLISSANDO PORTAMENT**

(PSW 44) POR.



**Clock OSC-Porta**

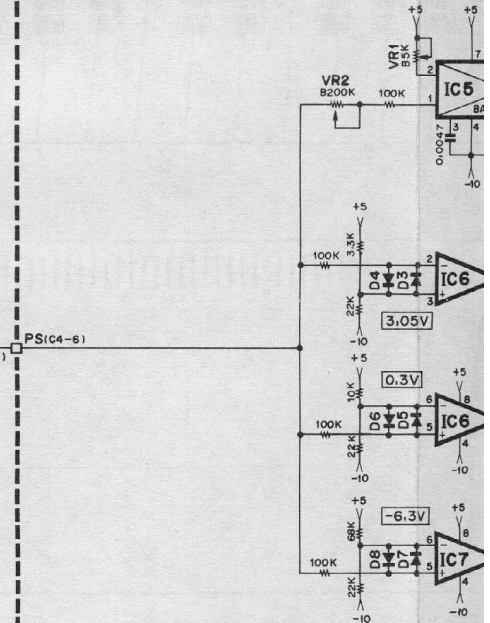

# SK Circuit Diagram

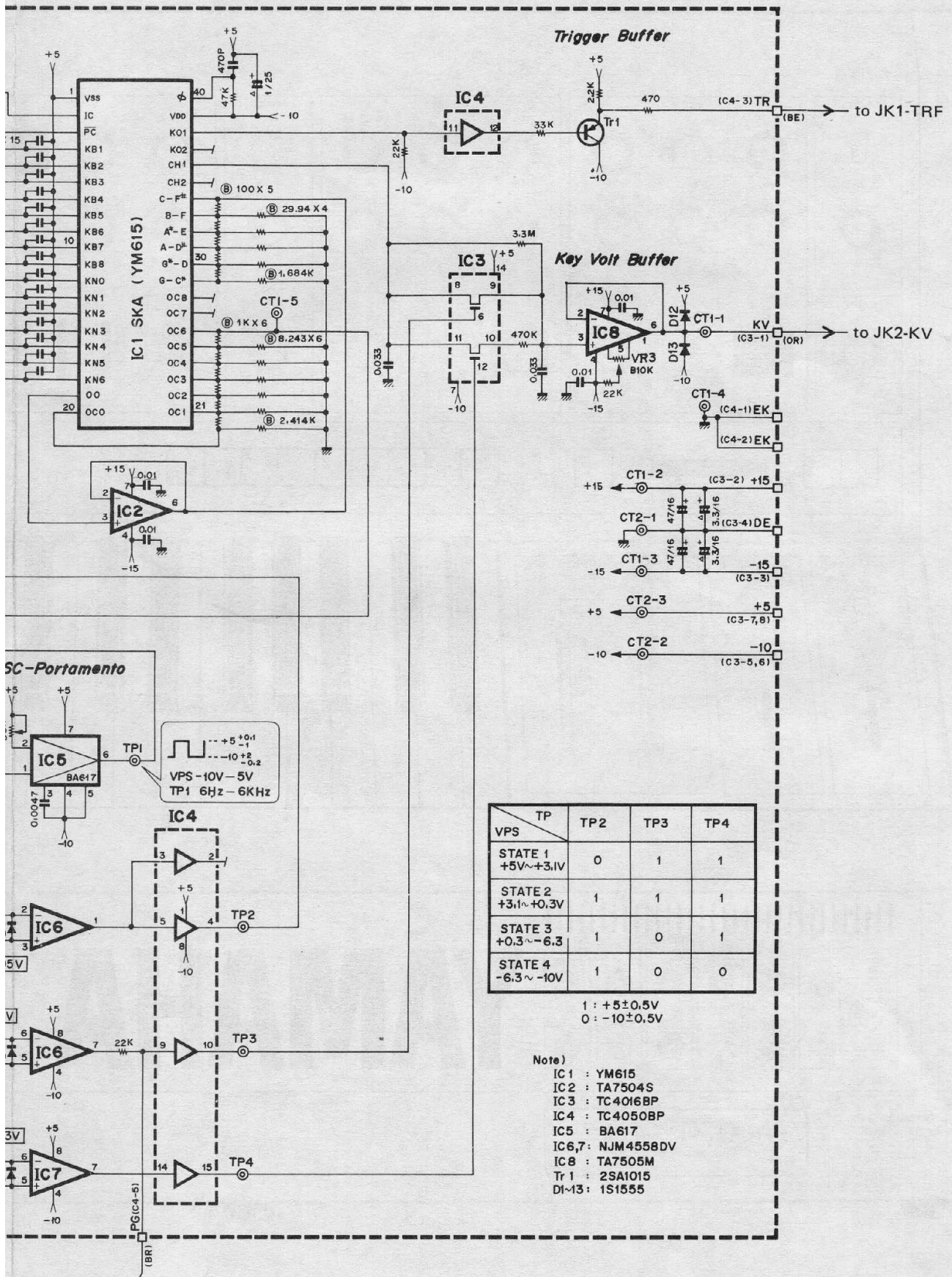

# SK Circuit Board & Wiring

**C1**

B6	1
B5	2
B4	3
B3	4
B2	5
B1	6

**C2**

N6	1
N5	2
N4	3
N3	4
N2	5
N1	6
N0	7

**CT1**

KV	1
+15	2
-15	3
EK	4
VR	5

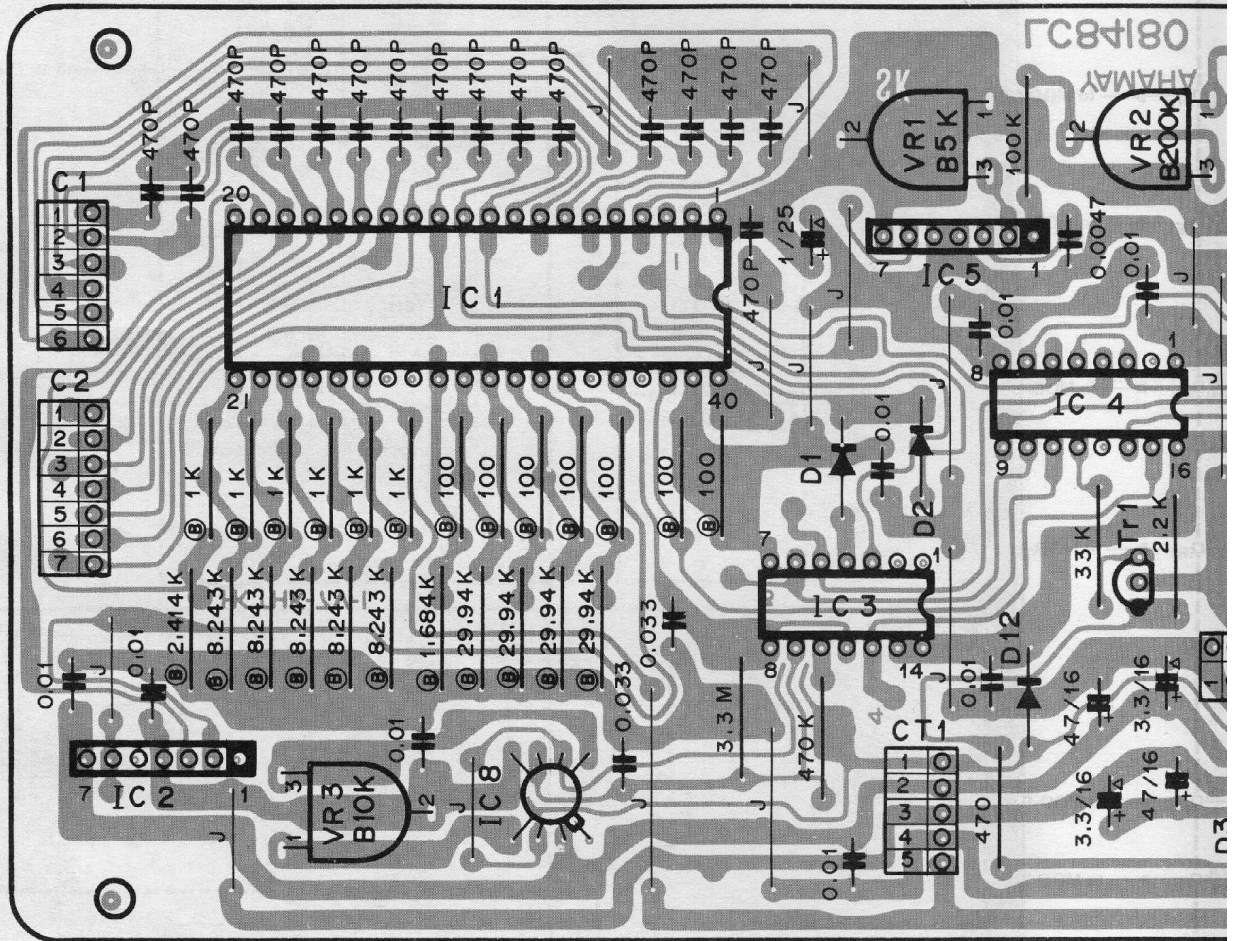

**C1**

Pin No.	Pin Name	Wire Color	Destination
1	B6	BE	MK-B6 (C1-6)
2	B5	GR	MK-B5 (C1-5)
3	B4	YE	MK-B4 (C1-4)
4	B3	OR	MK-B3 (C1-3)
5	B2	RE	MK-B2 (C1-2)
6	B1	BR	MK-B1 (C1-1)

**C2**

Pin No.	Pin Name	Wire Color	Destination
1	N6	PK	MK-F# (C2-5)
2	N5	SB	MK-F (C2-4)
3	N4	GG	MK-E (C2-3)
4	N3	WH	MK-D# (C2-2)
5	N2	GY	MK-D (C2-1)
6	N1	VI	MK-C# (C1-8)
7	N0	BL	MK-CL (C1-7)

**C3**

Pin No.	Pin Name	Wire Color	Destination
1	KV	OR	JK2-KV (C2-1)
2	+15	BR	DC+15 (C4-1)
3	-15	BR	DC-15 (C4-5)
4	DE	BL	DC-DE (C4-8)
5	-10	BE	DC-10 (C4-10)
6	-10	BE	PL-10 (C1-3)
7	+5	GR	DC+5 (C4-7)
8	+5	GR	PL+5 (C1-4)

**C4**

Pin No.	Pin Name	Wire Color	Destination
1	EK	BL	DC-AE (C4-3)
2	EK	BL	PL-EK (C2-6)
3	TR	BE	JK1-TRF (C2-7)
4	VR	RE	PL-VR (C2-1)
5	PG	BR	PL-PG (C1-5)
6	PS	BR	PL-POR (C1-1)

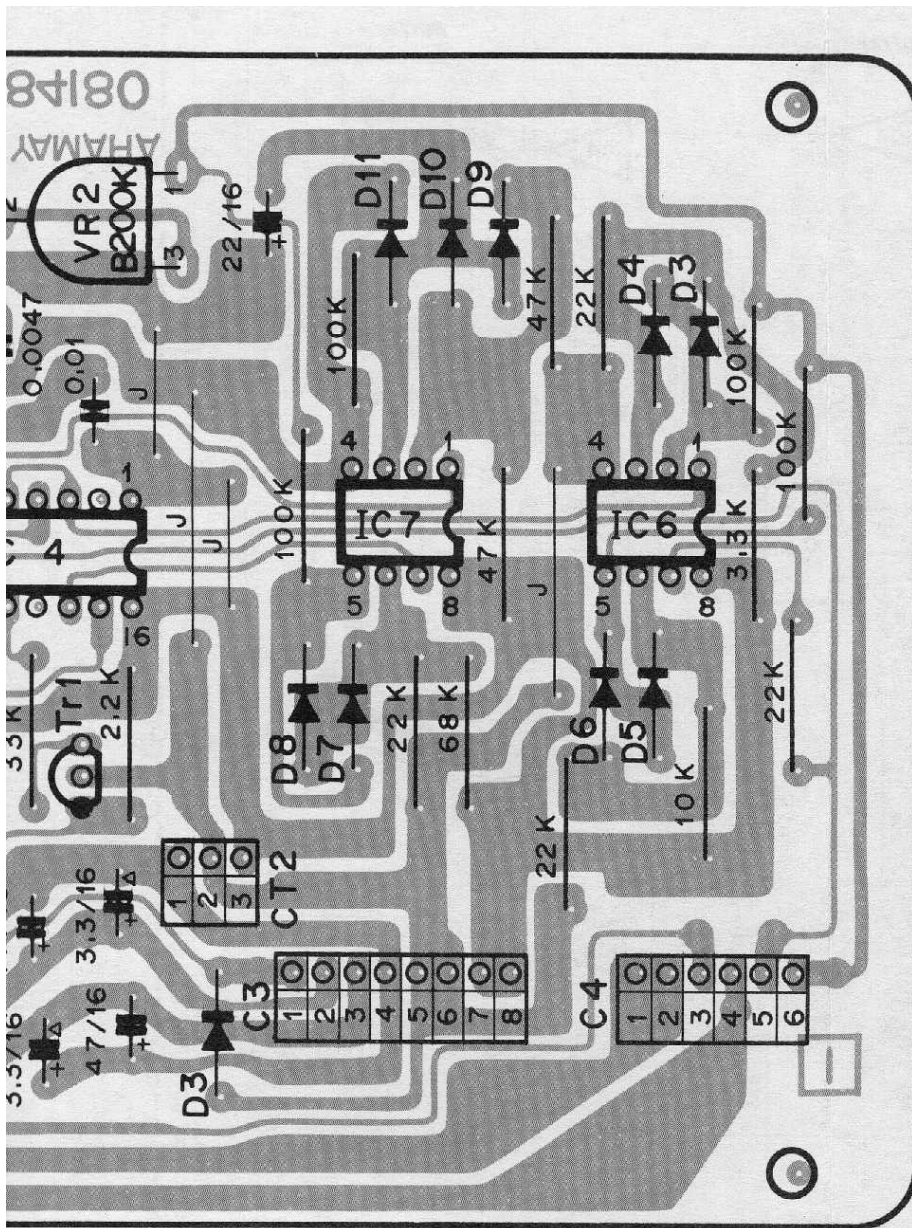

CT 2	1
DE	2
-10	3
+5	

KV	1
+15	2
-15	3
DE	4
-10	5
-10	6
+5	7
+5	8

C 3

C 4

EK	1
EK	2
TR	3
VR	4
PG	5
PS	6

Note)

1. Circuit Board : LC84181

2. IC

IC1 : YM615

IC2 : TA7504S

IC3 : TC4016BP

IC4 : TC4050BP

IC5 : BA617

IC6,7 : NJM4558DV

IC8 : TA7505M

3. Transistor

Tr1 : 2SA1015

4. Capacitor

△marked : Tantalum Capacitor

5. Diode

D1 ~ 13 : 1S1555

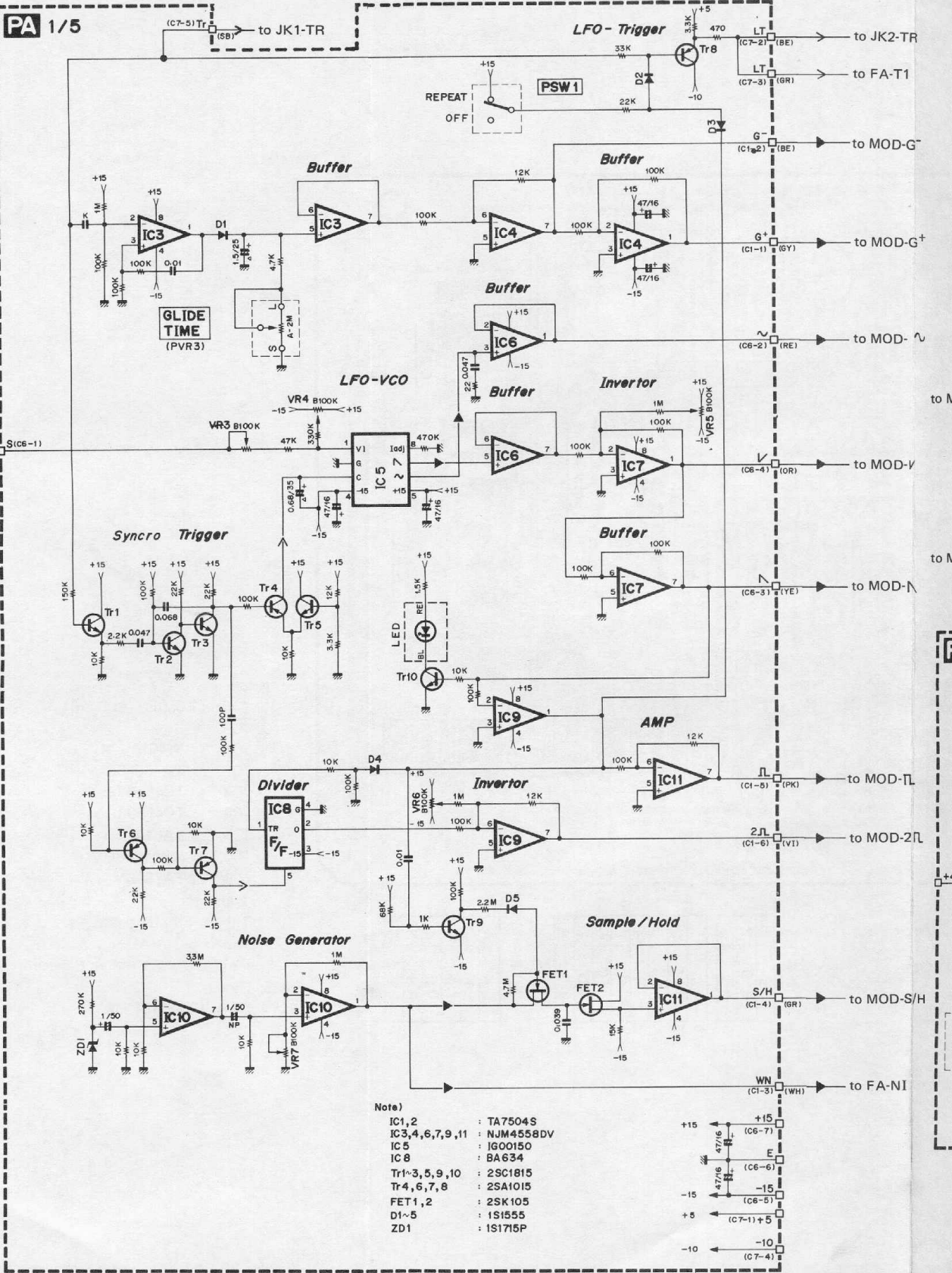

**PA 1/5**

from DM-1 (BR) → S(C6-1)

**GLIDE TIME**  
(PVR3)

**Syncro Trigger**

**LFO-VCO**

**LFO-Trigger**

**Noise Generator**

**Divider**

**AMP**

**Sample / Hold**

- Note)**
- IC1, 2 : TA7504S
  - IC3, 4, 6, 7, 9, 11 : NJM4558DV
  - IC5 : IGO0150
  - IC8 : BA634
  - Tr1~3, 5, 9, 10 : 2SC1815
  - Tr4, 6, 7, 8 : 2SA1015
  - FET1, 2 : 2SK105
  - D1~5 : 1S1555
  - ZD1 : 1S1715P

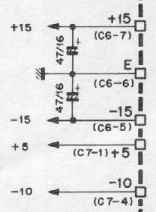

# PA Circuit Diagram

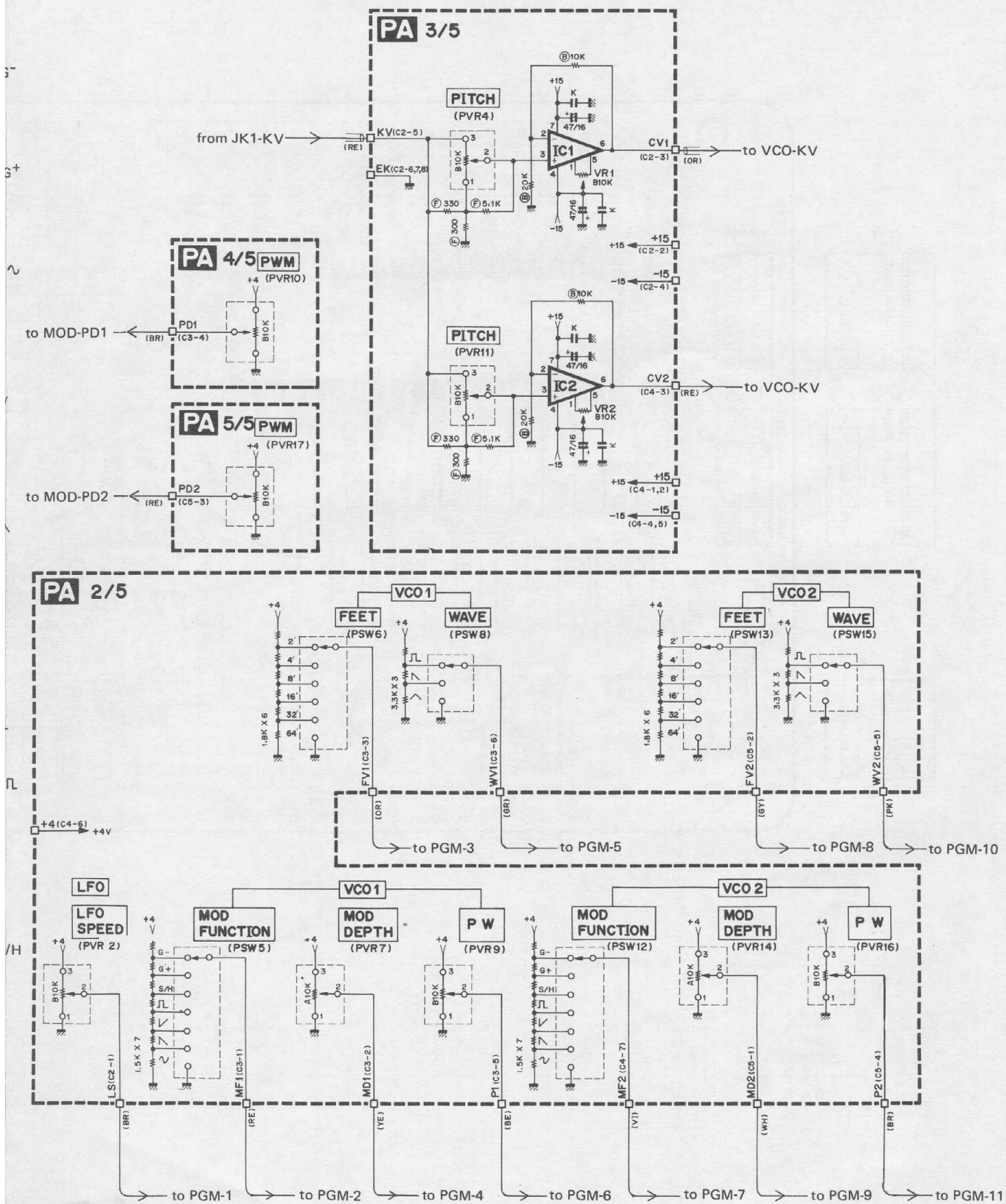

GCMK-36EY

YAMAHA  
PA  
LC 84190

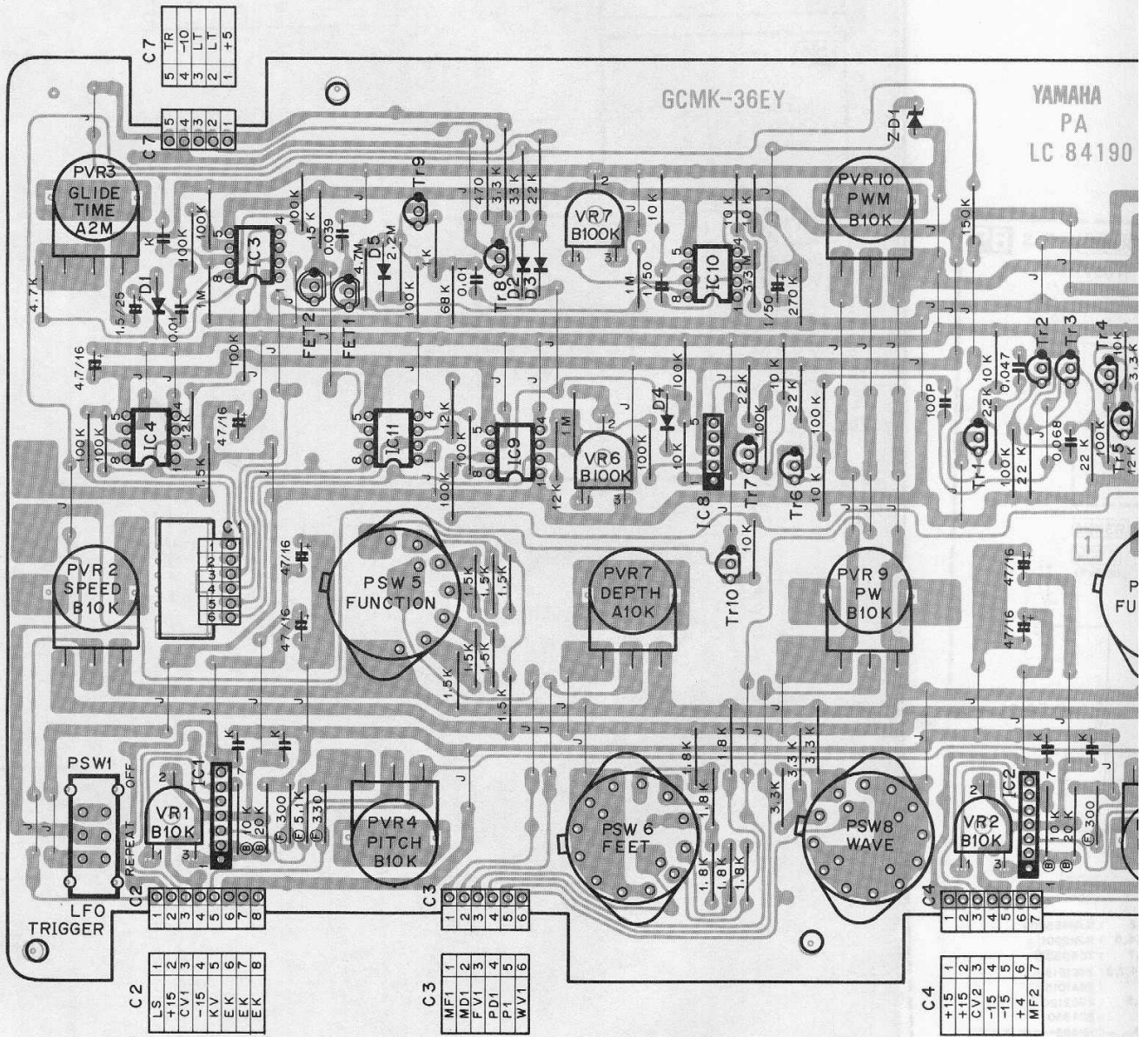

C1

G+	1
G-	2
WN	3
S/H	4
FL	5
2FL	6

C2

LS	1
+15	2
CV1	3
-15	4
KV	5
EK	6
EK	7
EK	8

C3

MF1	1
MD1	2
FV1	3
PD1	4
P1	5
WV1	6

C4

+15	1
+15	2
CV2	3
-15	4
-15	5
+4	6
MF2	7

YAMAHA  
PA  
84190

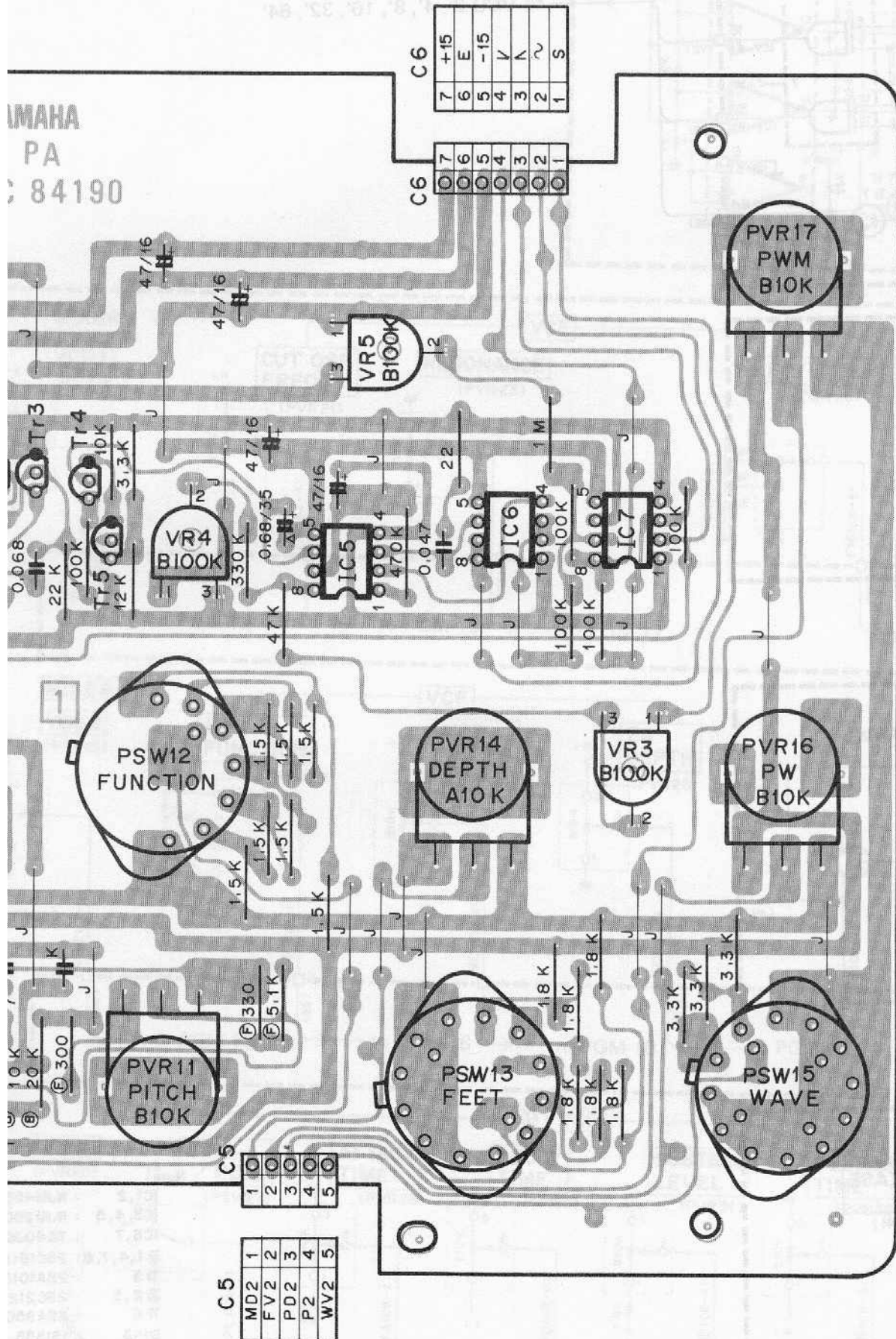

View from the printed pattern side of the circuit board

# PA Circuit Board & Wiring

C1

Pin No.	Pin Name	Wire Color	Destination
1	G <sup>+</sup>	GY	MOD-G <sup>+</sup> (C2-8)
2	G <sup>-</sup>	BE	MOD-G <sup>-</sup> (C2-6)
3	WN	SWH	FA-NI (C6-1)
4	S/H	GR	MOD-S/H (C2-5)
5	∟	WH	MOD-∟ (C2-3)
6	2 ∟	VI	MOD-2 ∟ (C2-7)

C6

Pin No.	Pin Name	Wire Color	Destination
1	S	BR	DM-1 (C5-9)
2	∩	RE	MOD-∩ (C2-1)
3	∟	YE	MOD-∟ (C2-4)
4	∨	OR	MOD-∨ (C2-2)
5	-15	YE	DC--15 (C1-5)
6	E	BL	DC-AE (C1-3)
7	+15	BR	DC+15 (C1-1)

C2

Pin No.	Pin Name	Wire Color	Destination
1	LS	BR	PGM-1 (C6-10)
2	+15	BR	PA+15 (C4-2)
3	CV1	SOR	VCO-KV (C2-2)
4	-15	YE	PA-15 (C4-5)
5	KV	SRE	JK1-KV (C2-1)
6	EK	SRES	
7	EK	BL	JK2-EK (C2-4)
8	EK	BL	VCO-EK (C1-1)

C7

Pin No.	Pin Name	Wire Color	Destination
1	+5	GR	PB+5 (C1-5)
2	LT	BE	JK2-TR (C2-5)
3	LT	GR	FA-TI (C3-6)
4	-10	BE	PB--10 (C1-2)
5	TR	SB	JK1-TR (C2-6)

C3

Pin No.	Pin Name	Wire Color	Destination
1	MF1	RE	PGM-2 (C6-9)
2	MD1	YE	PGM-4 (C6-7)
3	FV1	OR	PGM-3 (C6-8)
4	PD1	BR	MOD-PD1 (C3-3)
5	P1	BE	PGM-6 (C6-1)
6	WV1	GR	PGM-5 (C6-6)

C4

Pin No.	Pin Name	Wire Color	Destination
1	+15	BR	DC+15 (C3-1)
2	+15	BR	PA+15 (C2-2)
3	CV2	RE	VCO-KV (C1-2)
4	-15	YE	DC--15 (C3-5)
5	-15	YE	PA--15 (C2-4)
6	+4	VI	PB+4 (C3-4)
7	MF2	VI	PGM-7 (C6-2)

C5

Pin No.	Pin Name	Wire Color	Destination
1	MD2	WH	PGM-9 (C6-4)
2	FV2	GY	PGM-8 (C6-3)
3	PD2	RE	MOD-PD2 (C3-4)
4	P2	BR	PGM-11 (C8-1)
5	WV2	PK	PGM-10 (C6-5)

## Note)

1. Circuit Board : LC84191

2. IC

IC1, 2 : TA7504S

IC3, 4

6, 7

9, 10 : NJM4558DV

11

IC5 : iG00150

IC8 : BA634

3. Transistor

Tr1, 2, 3, 5, 9, 10 : 2SC1815

Tr4, 6, 7, 8 : 2SA1015

4. FET

FET1, 2 : 2SK105

5. Diode

D1 ~ 5 : 1S1555

6. Zenerdiode

ZD1 : 1S1715P

7. Capacitor

△ mark : Tantalum Capacitor

K mark : 1000P

8. Resistor

F marked : 1% 100PPM

B marked : 0.1% 25PPM

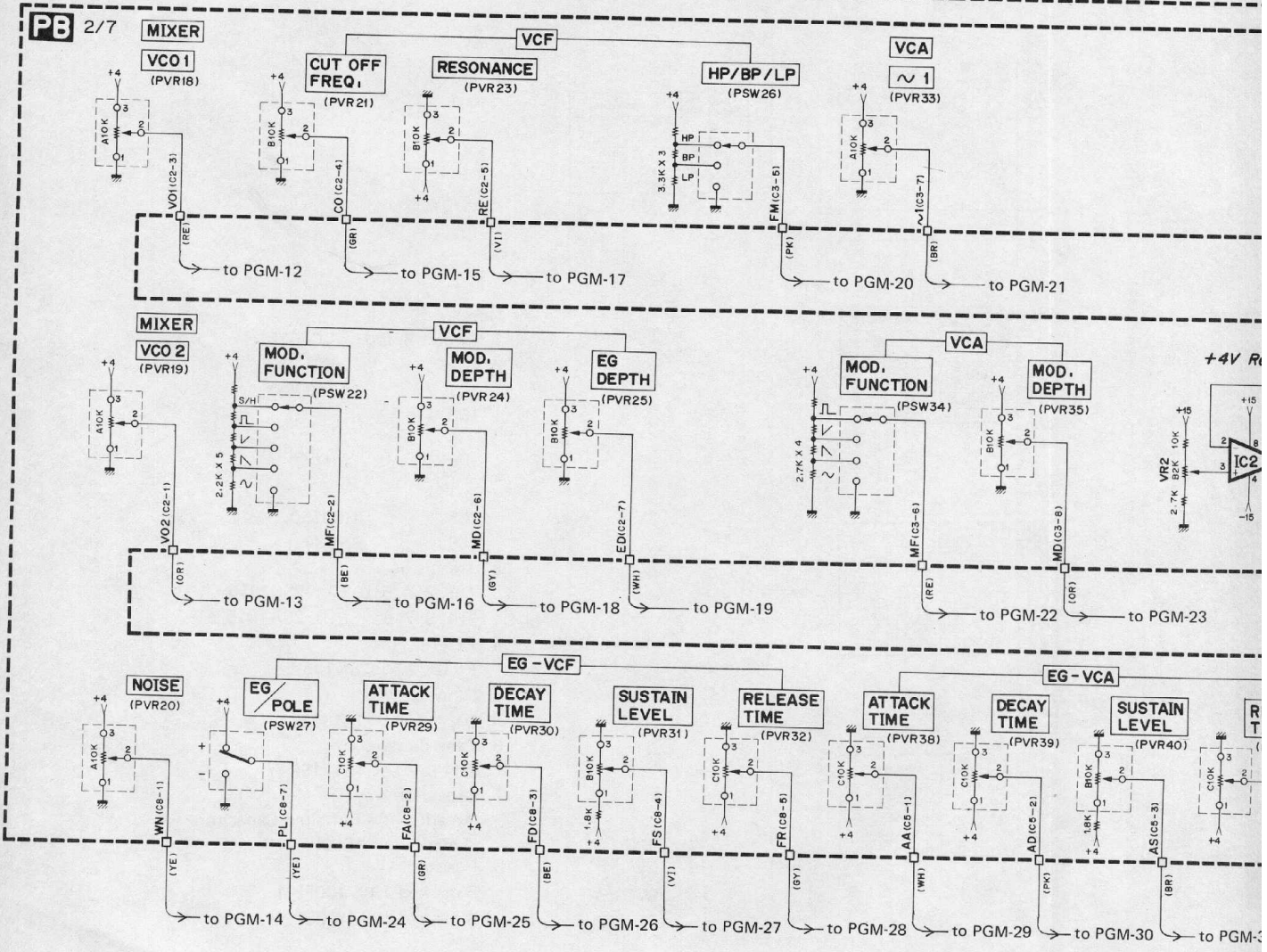
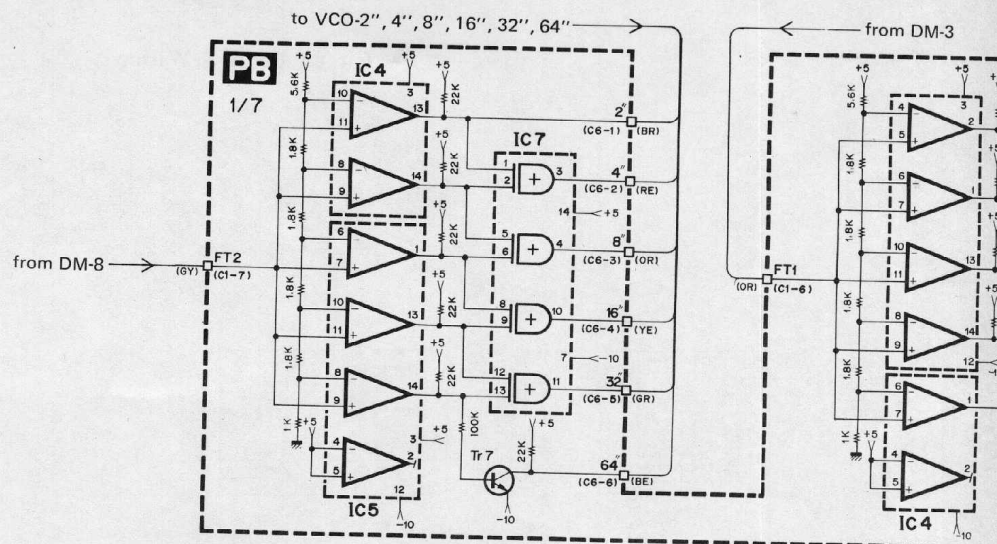

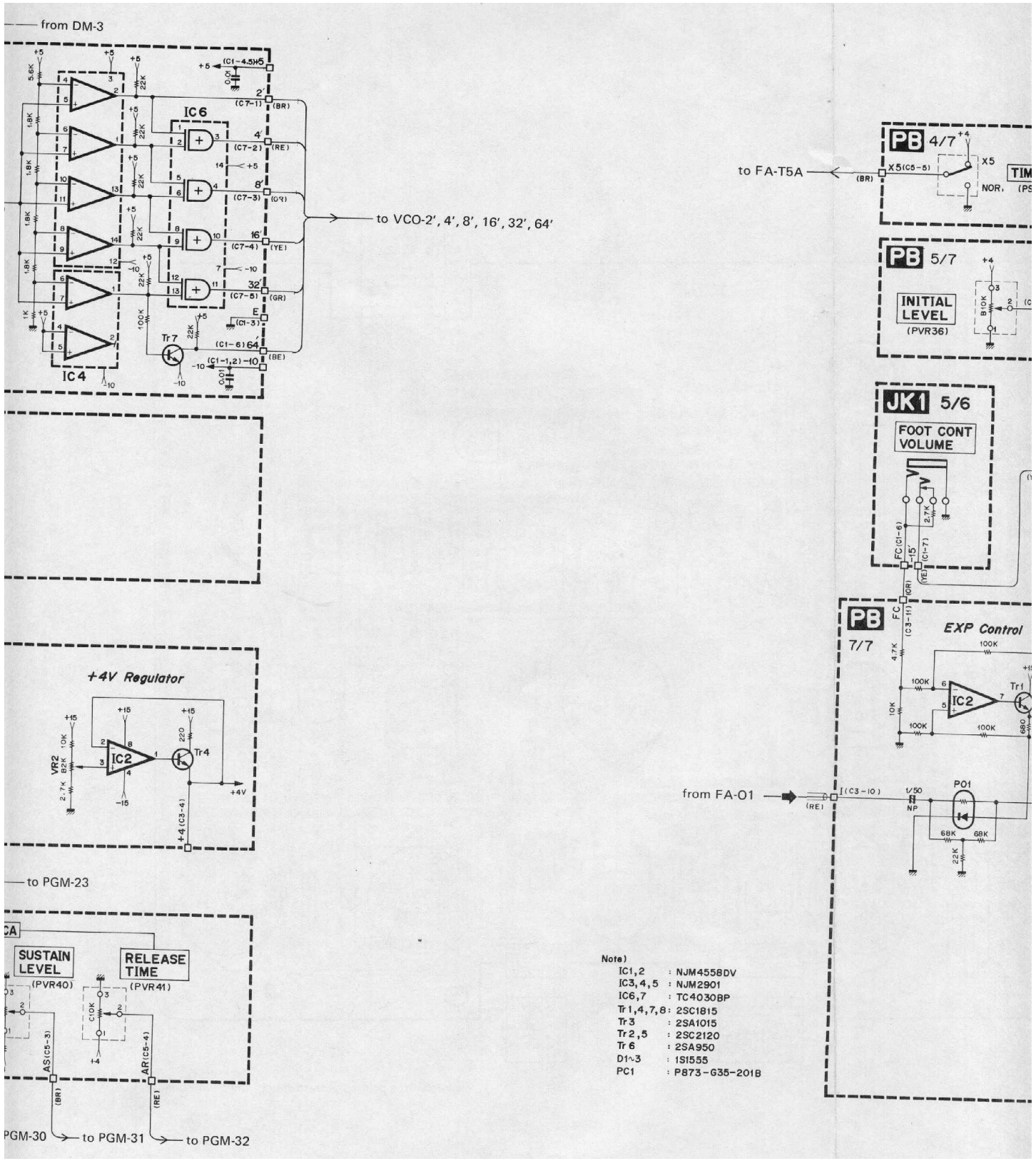

# PB Circuit Diagram

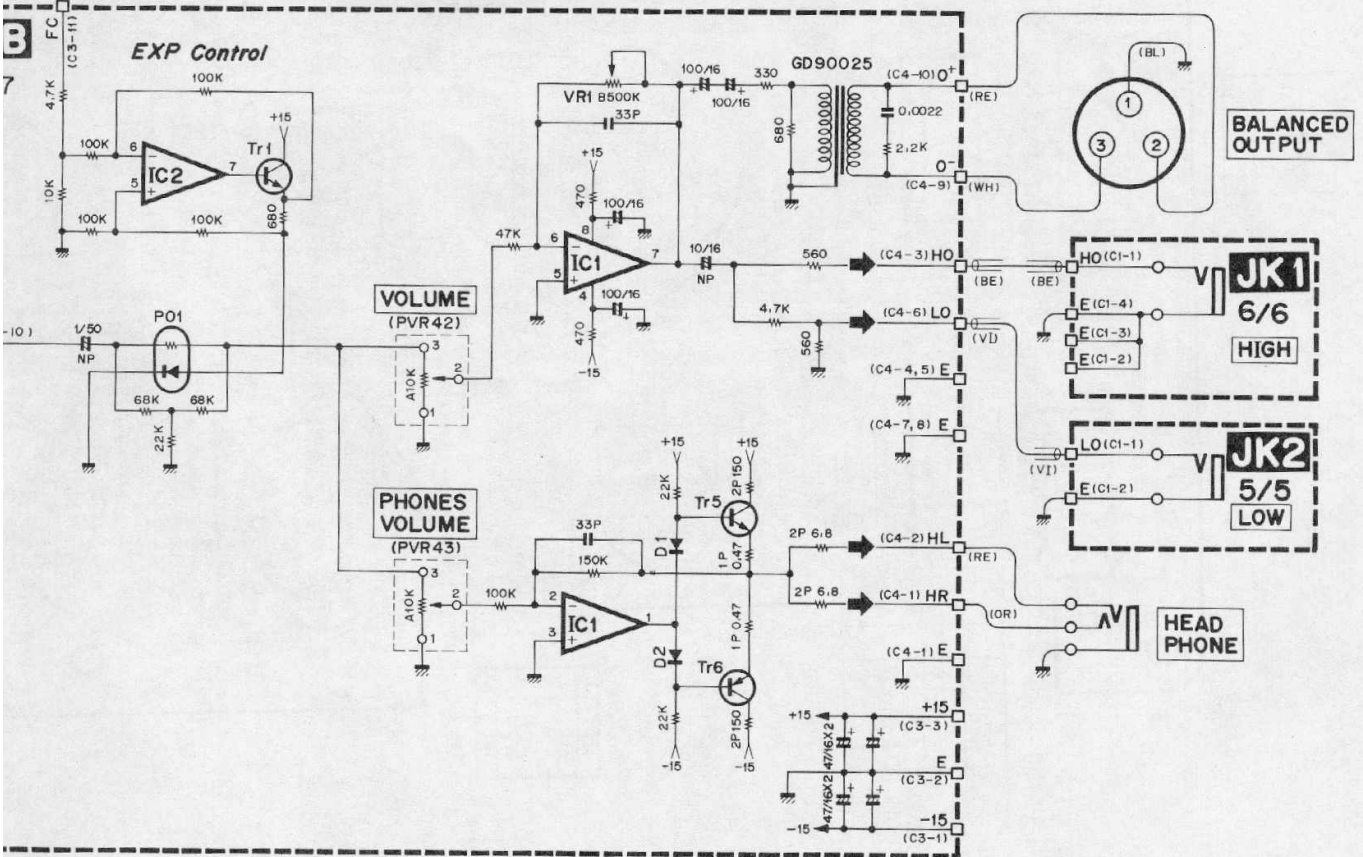
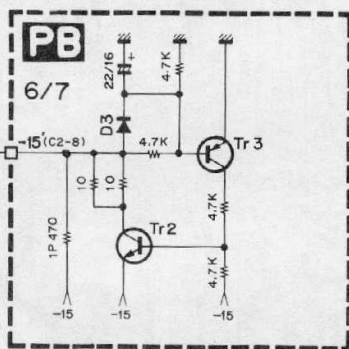
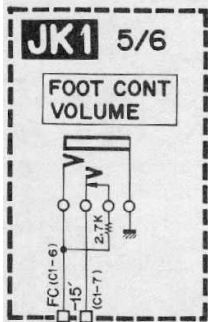
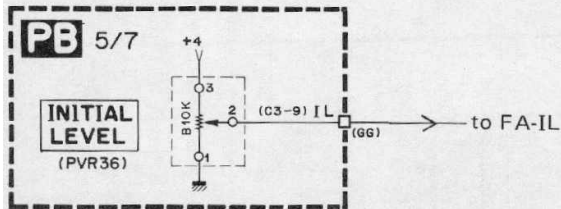
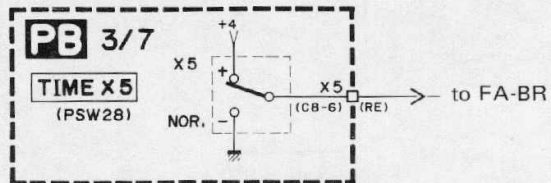
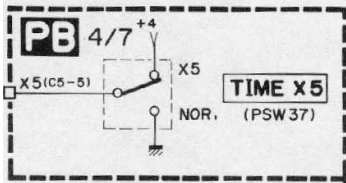

C1
AA
AD
AS
AR
X5

**C8**

WN	1
FA	2
FD	3
FR	4
X5	5
PL	7

**C6**

2"	1
4"	2
8"	3
16"	4
32"	5
64"	6

**C7**

2"	1
4"	2
8"	3
16"	4
32"	5
64"	6

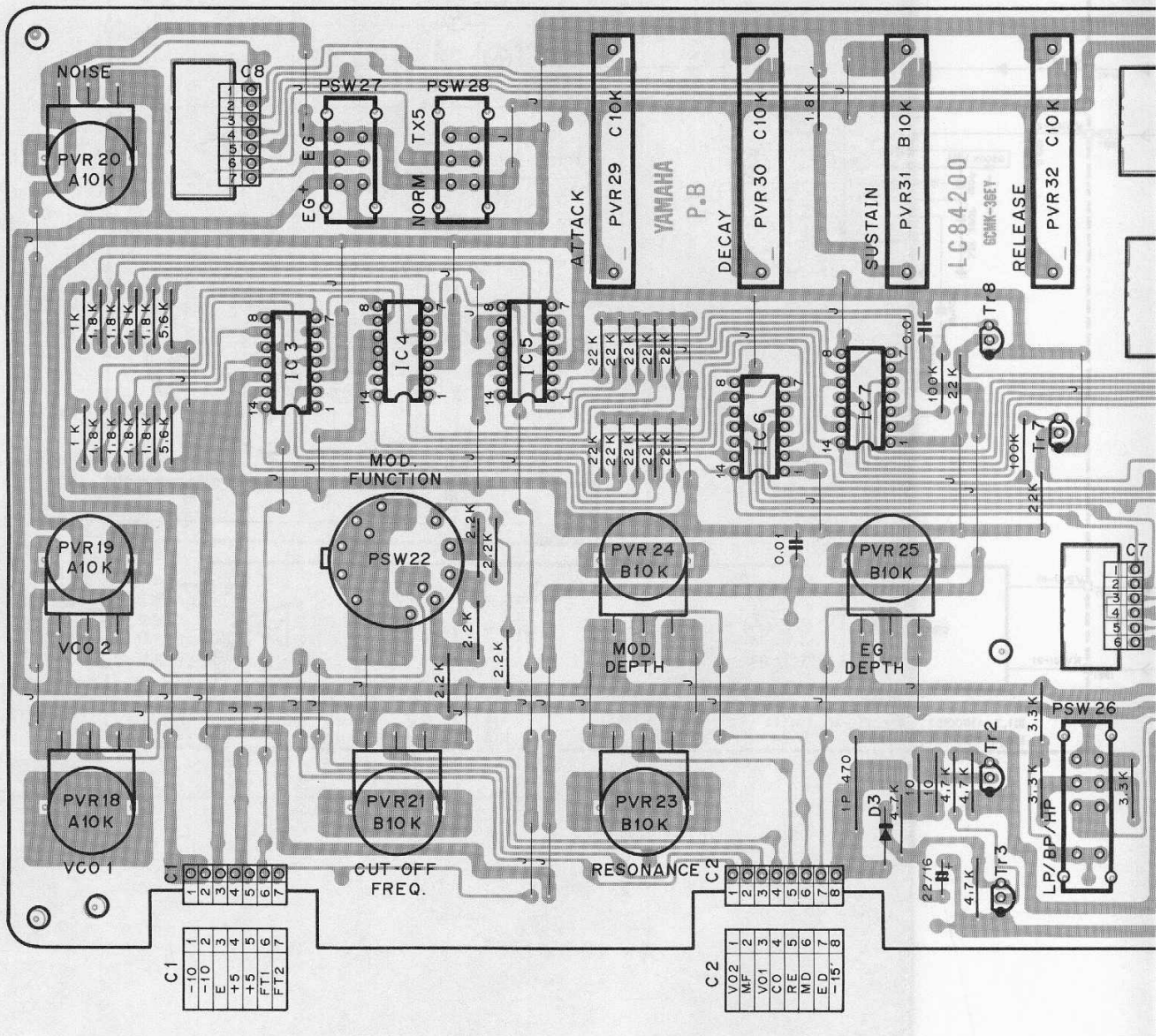

**C1**

1	0
2	0
3	0
4	0
5	0
6	0
7	0
8	0
9	0
10	1
-10	1
E	2
+5	4
+5	5
FTL	6
FTL	7

**C2**

1	0
2	0
3	0
4	0
5	0
6	0
7	0
8	0
-15	8
VO2	1
MF	2
VO1	3
CO	4
RE	5
MD	6
ED	7

**C7**

1	0
2	0
3	0
4	0
5	0
6	0
7	0

C5

AA	1
AD	2
AS	3
AR	4
X5	5

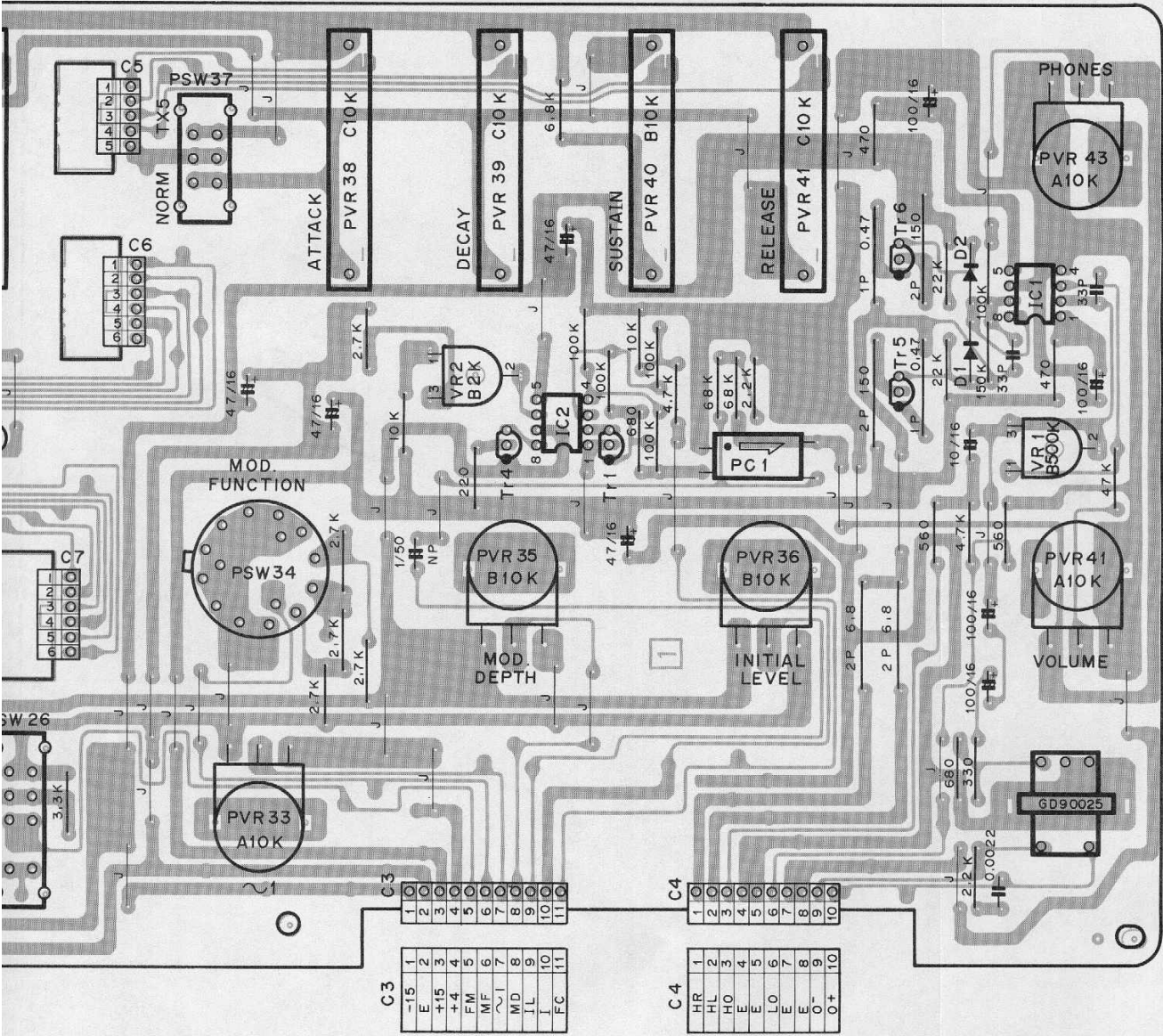

Pin No.	Pin Name
1	-10
2	-10
3	E
4	+5
5	+5
6	FT1
7	FT2

Pin No.	Pin Name
1	VO2
2	MF
3	VO1
4	CO
5	RE
6	MD
7	ED
8	-15'

Pin No.	Pin Name
1	-15
2	E
3	+15
4	+4
5	FM
6	MF
7	1
8	MD
9	IL
10	I
11	FC

Pin No.	Pin Name
1	HR
2	HL
3	HO
4	E
5	E
6	LO
7	E
8	E
9	O'
10	O'

Pin No.	Pin Name
1	AA
2	AD
3	AS
4	AR
5	X5

View from the printed pattern side of the circuit board

# PB Circuit Board & Wiring

C1

Pin No.	Pin Name	Wire Color	Destination
1	-10	BE	DC-10 (C1-10)
2	-10	BE	PA-10 (C7-4)
3	E	BL	DC-DE (C1-8)
4	+5	GR	DC+5 (C1-7)
5	+5	GR	PA+5 (C7-1)
6	FT1	OR	DM-3 (C5-7)
7	FT2	GY	DM-8 (C5-2)

C6

Pin No.	Pin Name	Wire Color	Destination
1	2"	BR	VCO-2" (C4-6)
2	4"	RE	VCO-4" (C4-5)
3	8"	OR	VCO-8" (C4-4)
4	16"	YE	VCO-16" (C4-3)
5	32"	GR	VCO-32" (C4-2)
6	64"	BE	VCO-64" (C4-1)

C2

Pin No.	Pin Name	Wire Color	Destination
1	VO2	OR	PGM-13 (C7-8)
2	MF	BE	PGM-16 (C7-5)
3	VO1	RE	PGM-12 (C7-9)
4	CO	GR	PGM-15 (C7-6)
5	RE	VI	PGM-17 (C7-4)
6	MD	GY	PGM-18 (C7-3)
7	ED	WH	PGM-19 (C7-2)
8	-15'	YE	JK1--15' (C1-7)

C7

Pin No.	Pin Name	Wire Color	Destination
1	2'	BR	VCO-2' (C3-6)
2	4'	RE	VCO-4' (C3-5)
3	8'	OR	VCO-8' (C3-4)
4	16'	YE	VCO-16' (C3-3)
5	32'	GR	VCO-32' (C3-2)
6	64'	BE	VCO-64' (C3-1)

C3

Pin No.	Pin Name	Wire Color	Destination
1	-15	YE	DC-15 (C1-6)
2	E	BL	DC-AE (C1-4)
3	+15	BR	DC+15 (C1-2)
4	+4	VI	PA+4 (C4-6)
5	FM	PK	PGM-20 (C7-1)
6	MF	RE	PGM-22 (C9-3)
7	1	BR	PGM-21 (C9-4)
8	MD	OR	PGM-23 (C9-2)
9	IL	GG	FA-IL (C3-2)
10	I	SRE	FA-O1 (C5-1)
11	FC	OR	JK1-PC (C1-6)

C8

Pin No.	Pin Name	Wire Color	Destination
1	WN	YE	PGM-14 (C7-7)
2	FA	GR	PGM-25 (C8-7)
3	FD	BE	PGM-26 (C8-2)
4	FS	VI	PGM-27 (C8-3)
5	FR	GY	PGM-28 (C8-4)
6	X5	RE	FA-T5F (C3-5)
7	PL	YE	PGM-24 (C9-1)

C4

Pin No.	Pin Name	Wire Color	Destination
1	HR	RE	HP-HR
2	HL	OR	HP-HL
3	HO	SBE	JK1-HO (C1-1)
4	E	SBES	
5	E	SVIS	
6	LO	SVI	SK2-LO (C1-1)
7	E	BL	JK1-E (C1-4)
8	E	BL	FA-E (C5-3)
9	O <sup>-</sup>	RE	XLR-3
10	O <sup>+</sup>	WH	XLR-2

C5

Pin No.	Pin Name	Wire Color	Destination
1	AA	WH	PGM-29 (C8-5)
2	AD	PK	PGM-30 (C8-6)
3	AS	BR	PGM-31 (C9-6)
4	AR	RE	PGM-32 (C9-5)
5	X5	BR	FA-T5A (C3-4)

## Note)

- Circuit Board : LC84201
- IC
  - IC1, 2 : NJM4558DV
  - IC3, 4, 5 : NJM2901
  - IC6, 7 : TC4030BP
- Transistor
  - Tr1, 4, 7, 8 : 2SC1815
  - Tr3 : 2SA1015
  - Tr2, 5 : 2SC2120
  - Tr6 : 2SA950
- Diode
  - D1, 2, 3 : 1S1555

# VCO Circuit Diagram

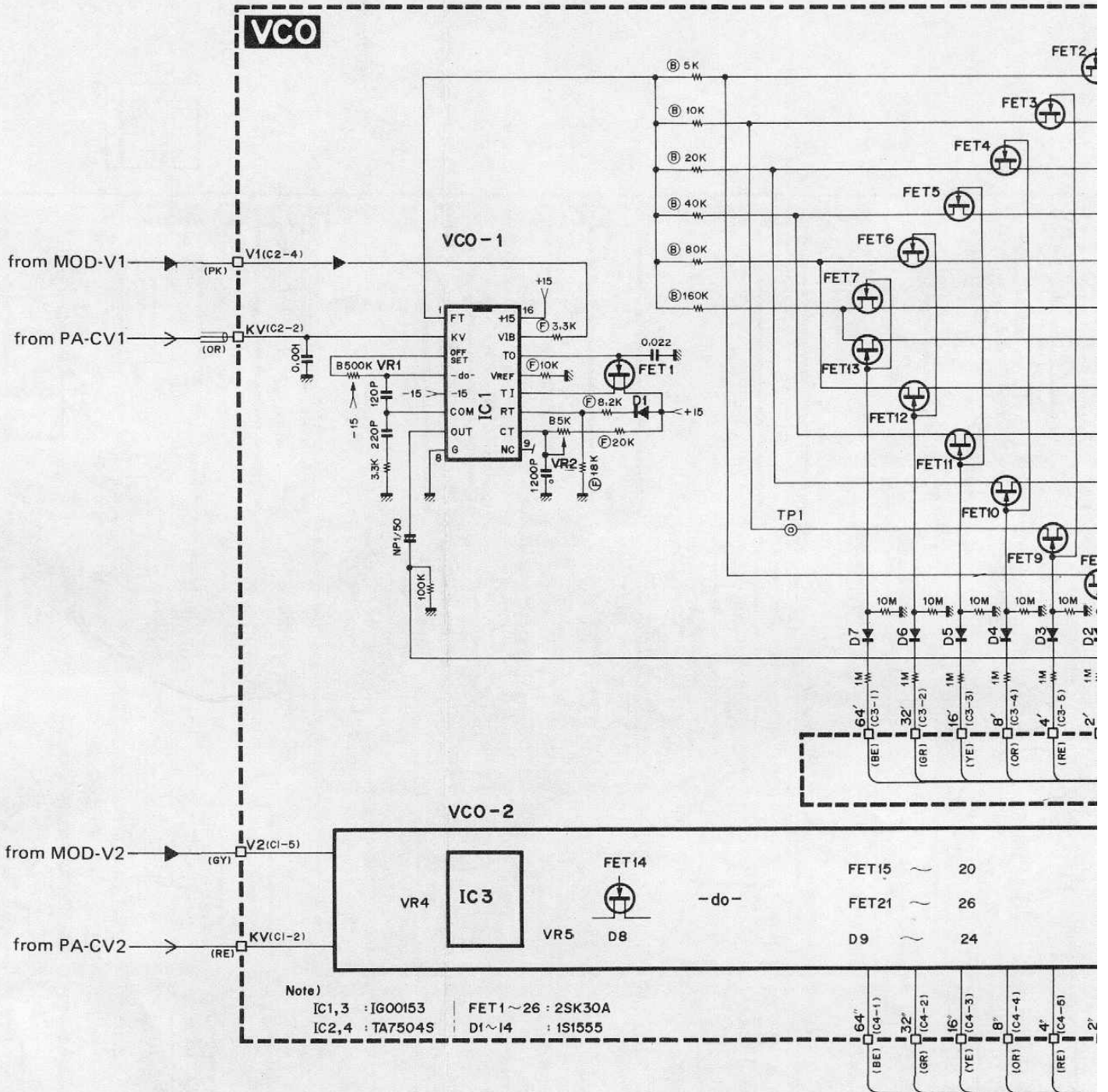

# Diagram

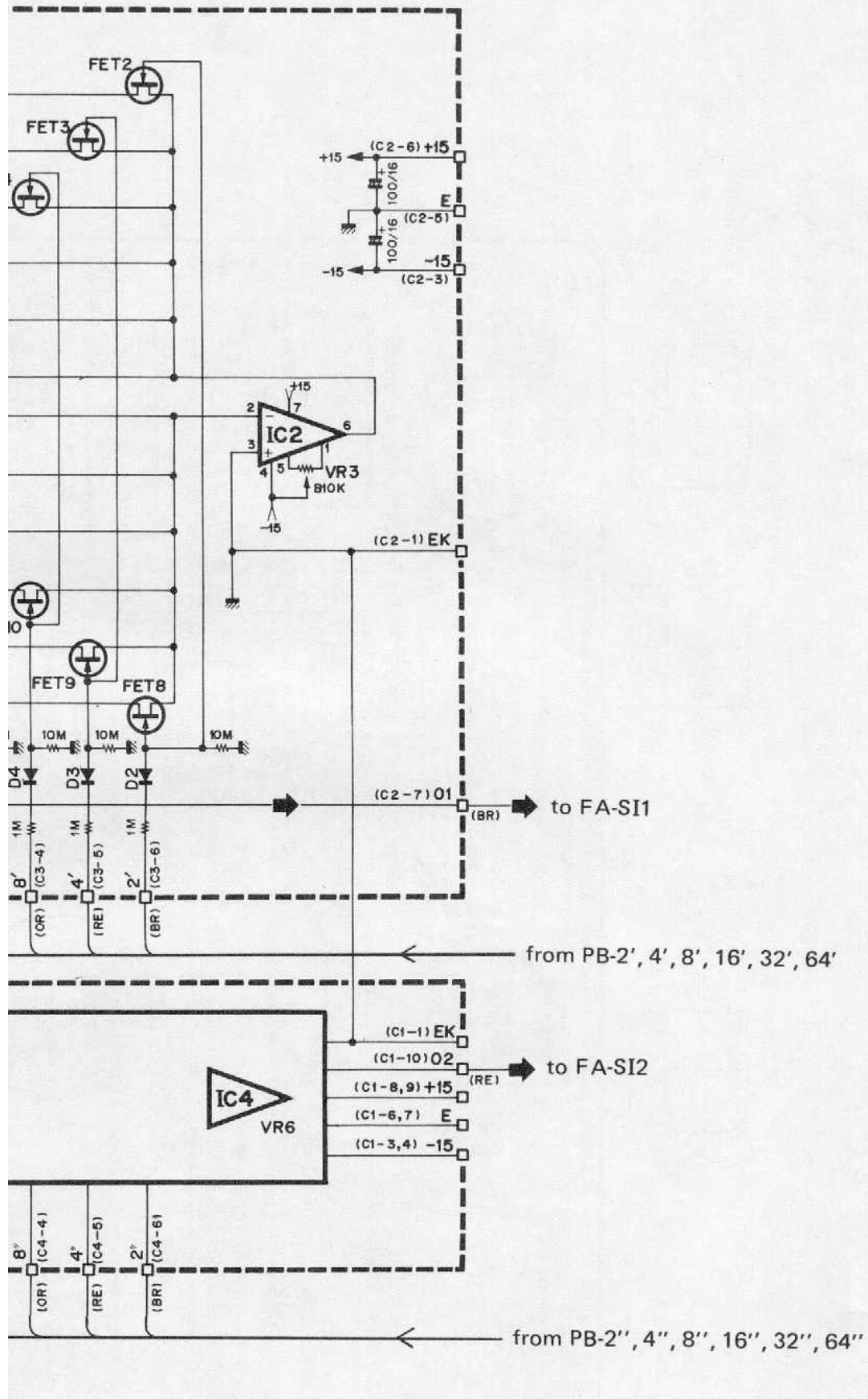



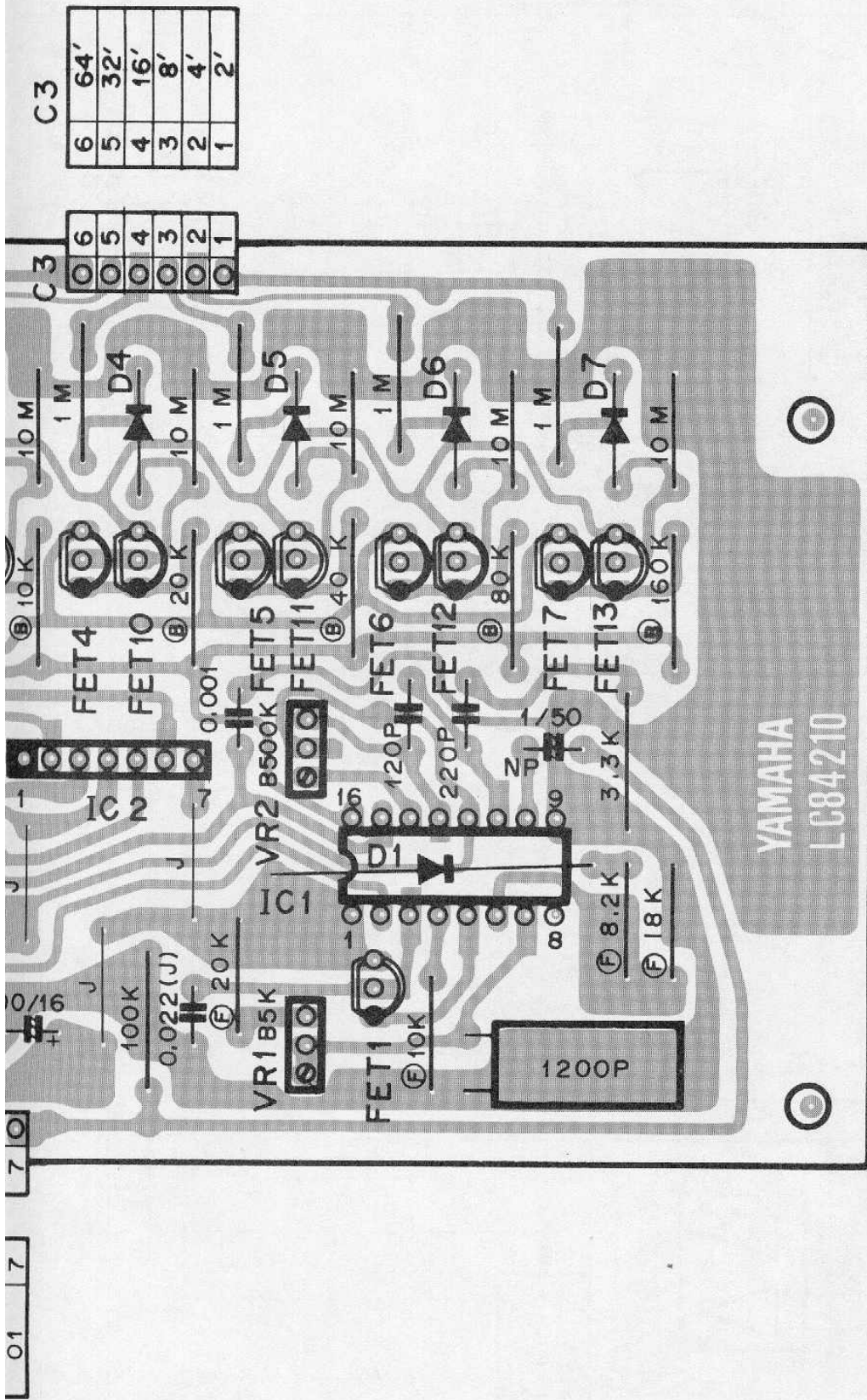

C1

Pin No.	Pin Name	Wire Color	Destination
1	EK	BL	PA-EK (C2-8)
2	KV	RE	PA-CV2 (C4-3)
3	-15	YE	DC-15 (C3-6)
4	-15	YE	VCO-15 (C2-3)
5	V2	GY	MOD-V2 (C4-5)
6	E	BL	DC-AE (C3-4)
7	E	BL	VCO-E (C2-5)
8	+15	BR	DC+15 (C3-2)
9	+15	BR	VCO+15 (C2-6)
10	O2	RE	FA-SI2 (C1-3)

C2

Pin No.	Pin Name	Wire Color	Destination
1	EK	SORS	
2	KV	SOR	PA-CV1 (C2-3)
3	-15	YE	VCO-15 (C1-4)
4	V1	PK	MOD-V1 (C4-8)
5	E	BL	VCO-E (C1-7)
6	+15	BR	VCO+15 (C1-9)
7	O1	BR	FA-SI1 (C1-1)

C3

Pin No.	Pin Name	Wire Color	Destination
1	64'	BE	PB-64' (C7-6)
2	32'	GR	PB-32' (C7-5)
3	16'	YE	PB-16' (C7-4)
4	8'	OR	PB-8' (C7-3)
5	4'	RE	PB-4' (C7-2)
6	2'	BR	PB-2' (C7-1)

C4

Pin No.	Pin Name	Wire Color	Destination
1	64''	BE	PB-64'' (C6-6)
2	32''	GR	PB-32'' (C6-5)
3	16''	YE	PB-16'' (C6-4)
4	8''	OR	PB-8'' (C6-3)
5	4''	RE	PB-4'' (C6-2)
6	2''	BR	PB-2'' (C6-1)

# VCO Circuit Board & Wiring

Note)

1. Circuit Board : LC84211

2. IC

I IC1, 3 : iG00153

IC2, 4 : TA7504S

3. Diode

D1 ~ 14 : 1S1555

4. FET

FET1 ~ 26 : 2SK30A

5. Resistor

ⓕmarked : 1% 100PPM

ⓑmarked : 0.1% 25PPM

## JK1 Circuit Diagram

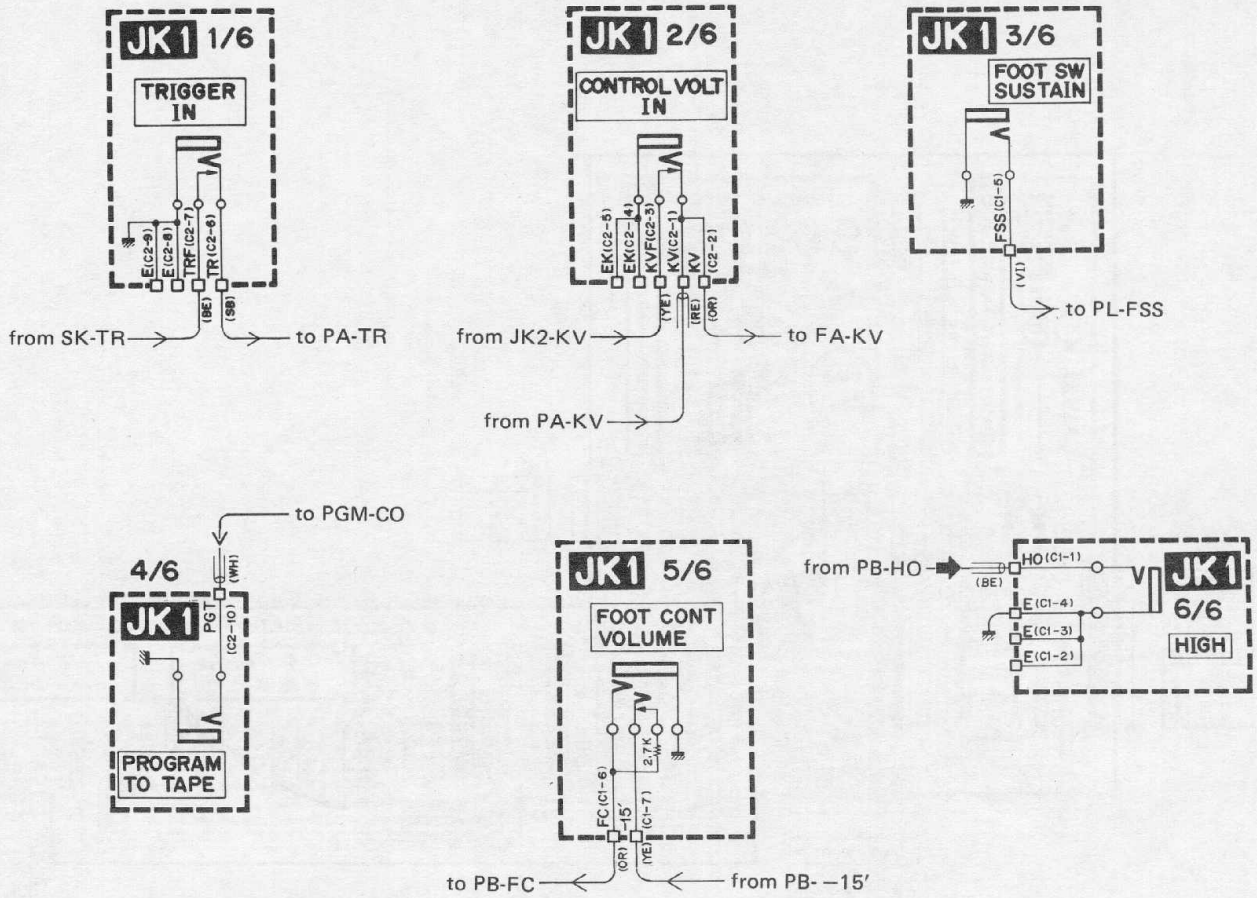

## JK2 Circuit Diagram

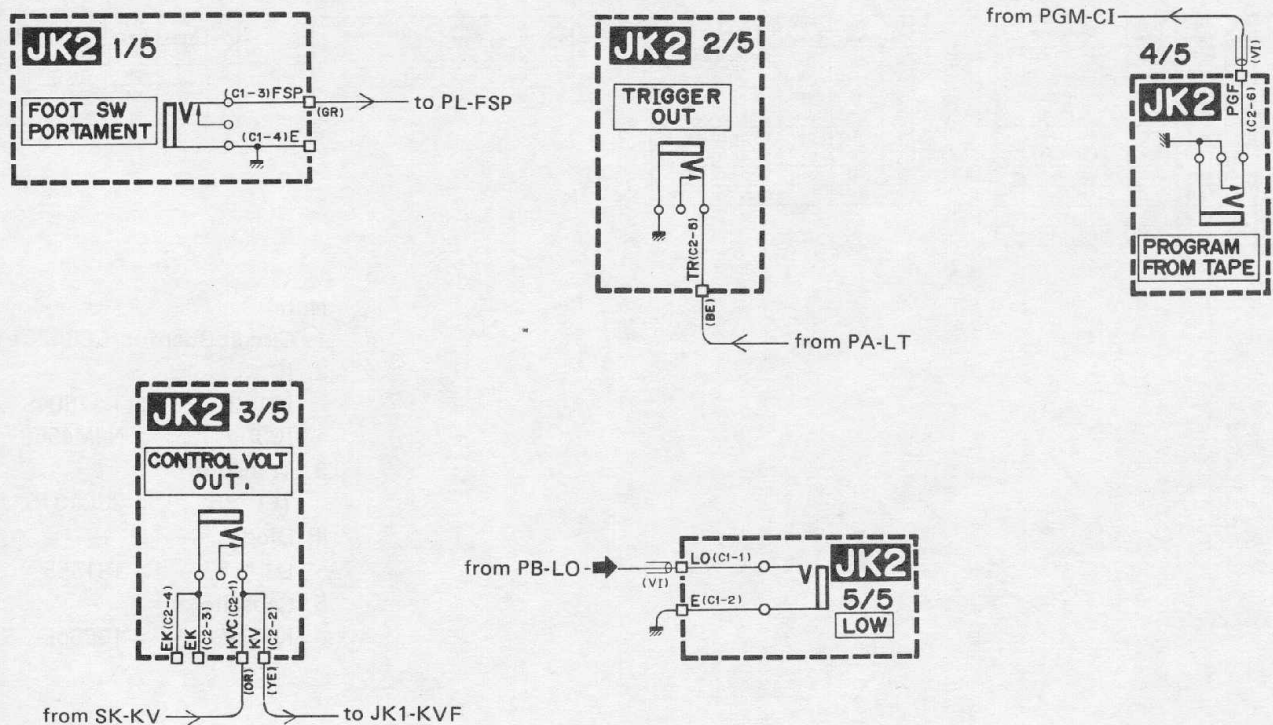

# JK1 Circuit Board & Wiring

# JK2 Circuit Board & Wiring

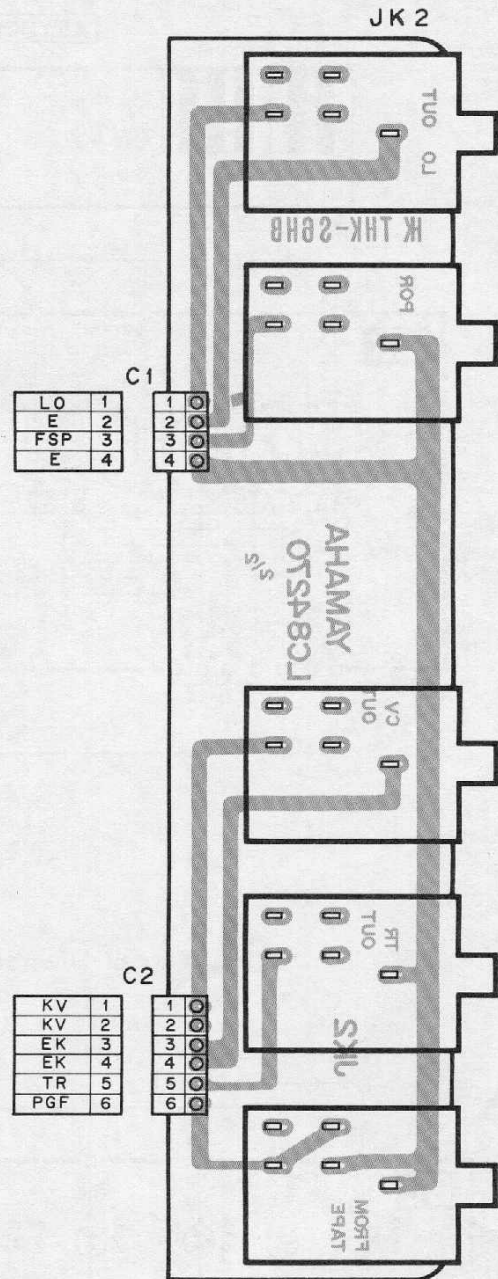
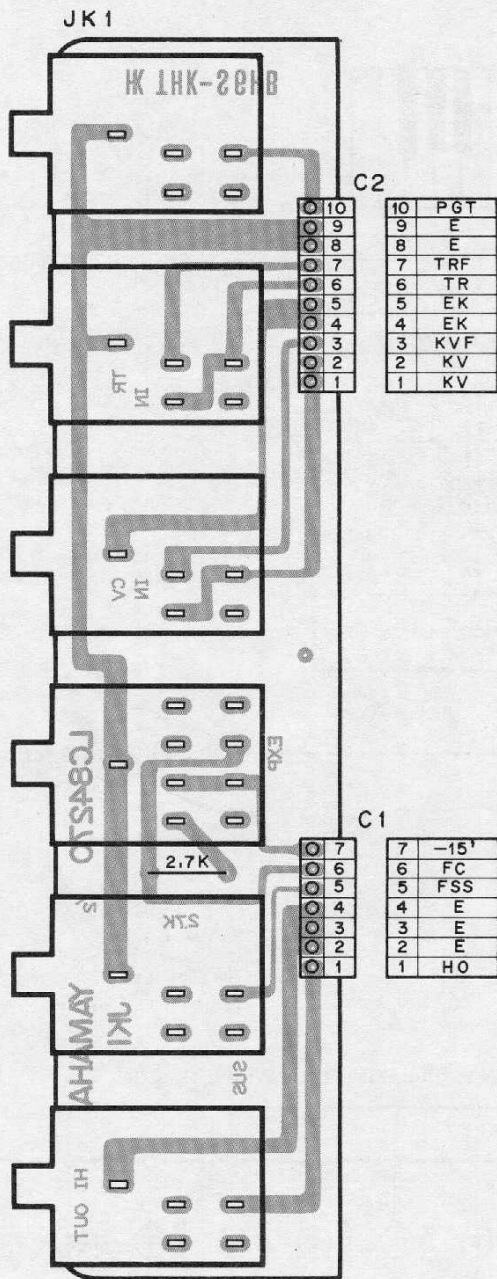

**C1**

Pin No.	Pin Name	Wire Color	Destination
1	HO	SBE	PB-HO (C4-3)
2	E	SBES	
3	E	BL	DC-DE (C2-9)
4	E	BL	PB-E (C4-7)
5	FSS	VI	PL-FSS (C1-10)
6	FC	OR	PB-FC (C3-11)
7	-15'	YE	PB.-15' (C2-8)

**C2**

Pin No.	Pin Name	Wire Color	Destination
1	KV	SRE	PA-KV (C2-5)
2	KV	OR	FA-KV (C5-5)
3	KVF	YE	JK2-KV (C2-2)
4	EK	BL	DC-AE (C4-4)
5	EK	BL	JK2-KE (C2-3)
6	TR	SB	PA-TR (C7-5)
7	TRF	BE	SK-TR (C4-3)
8	E	BL	DC-DE (C1-9)
9	E	BL	JK2-E (C1-4)
10	PGT	SWH	PGM-CO (C4-7)

**C1**

Pin No.	Pin Name	Wire Color	Destination
1	LO	SVI	PB-LO (C4-6)
2	E	SVIS	
3	FSP	GR	PL-RSP (C1-2)
4	E	BL	JK1-E (C2-9)

**C2**

Pin No.	Pin Name	Wire Color	Destination
1	KV	OR	SK-KV (C3-1)
2	KV	YE	JK1-KVF (C2-3)
3	EK	BL	JK1-EK (C2-5)
4	EK	BL	PA-EK (C2-7)
5	TR	BE	PA-LT (C7-2)
6	PGF	SVI	PGM-CI (C4-9)

Note)

1. Circuit Board : LC84270

# MK Circuit Diagram

## KEYBOARD (C3-C6)

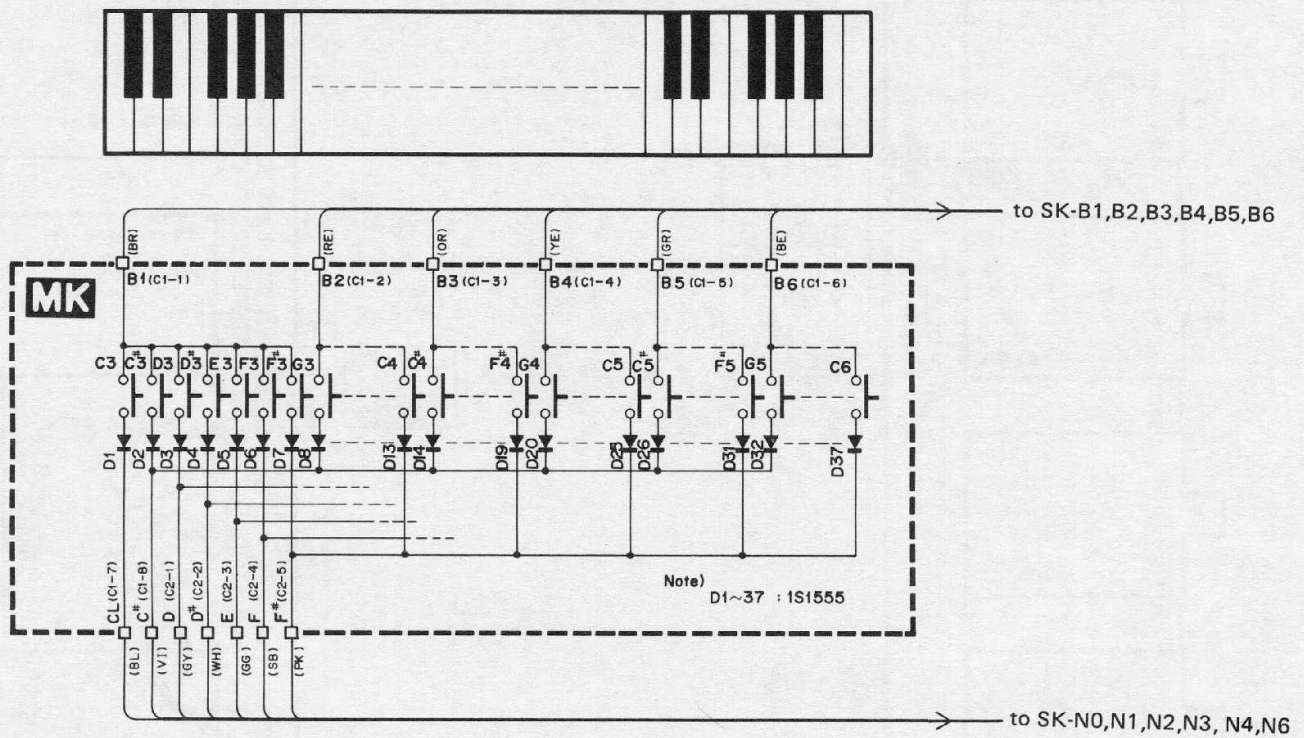

# BL Circuit Diagram

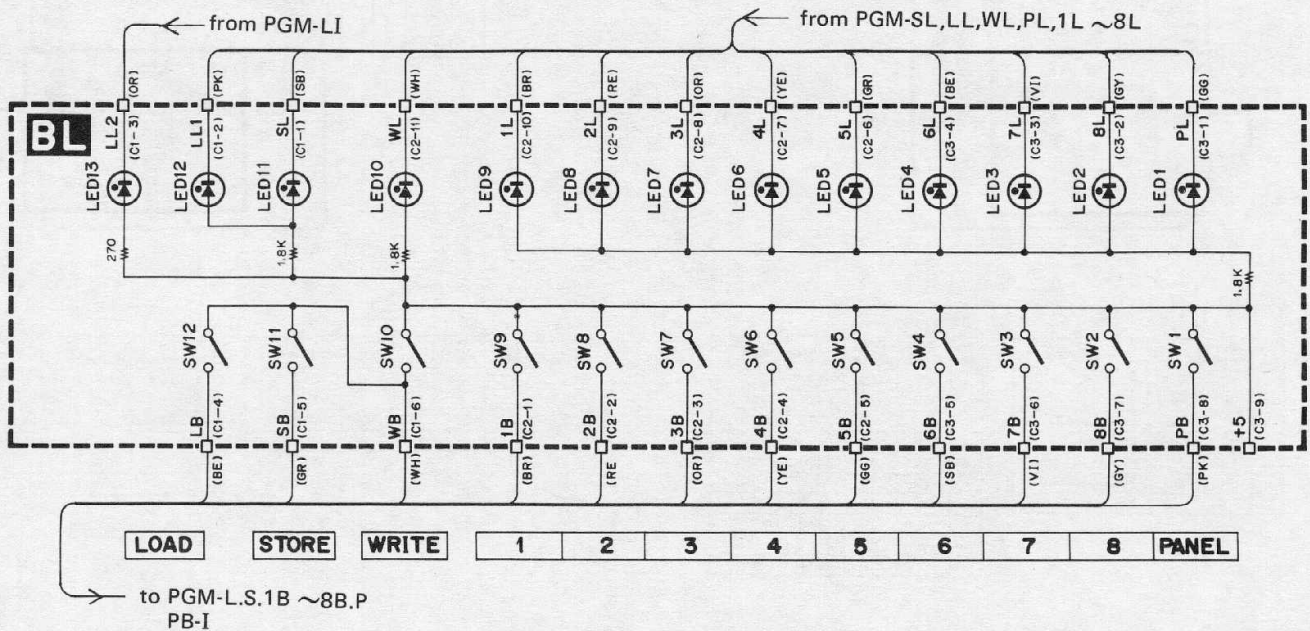

# BL Circuit Board & Wiring

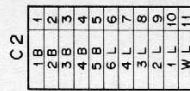
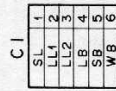
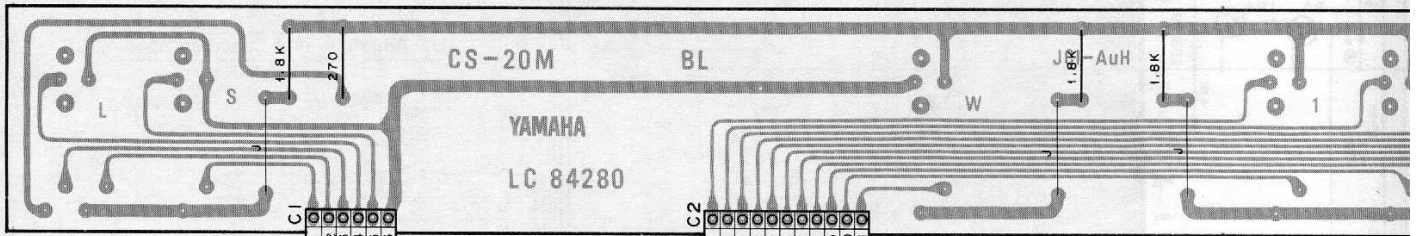

C1

C2

C3

Pin No.	Pin Name	Wire Color	Destination
1	SL	SB	PGM-SL (C3-5)
2	LL1	PK	PGM-LL (C3-4)
3	LL2	OR	PGM-LI (C4-5)
4	LB	BE	PGM-L (C10-8)
5	SB	GR	PGM-S (C10-7)
6	WB	WH	PGM-W (C10-6)

Pin No.	Pin Name	Wire Color	Destination
1	1B	BR	PGM-1B (C1-1)
2	2B	RE	PGM-2B (C1-2)
3	3B	OR	PGM-3B (C1-3)
4	4B	YE	PGM-4B (C1-4)
5	5B	GG	PGM-5B (C1-5)
6	5L	GR	PGM-5L (C2-6)
7	4L	YE	PGM-4L (C2-3)
8	3L	OR	PGM-3L (C2-4)
9	2L	RE	PGM-2L (C2-2)
10	1L	BR	PGM-1L (C2-5)
11	WL	WH	PGM-WL (C3-1)

Pin No.	Pin Name	Wire Color	Destination
1	PL	GG	PGM-PL (C3-2)
2	8L	GY	PGM-8L (C2-1)
3	7L	VI	PGM-7L (C2-7)
4	6L	BE	PGM-6L (C3-3)
5	6B	SB	PGM-6B (C1-6)
6	7B	VI	PGM-7B (C1-7)
7	8B	GY	PGM-8B (C1-8)
8	PB	PK	PGM-P (C10-5)
9	+5	GR	DM-+5 (C1-3)

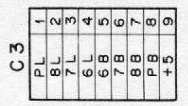
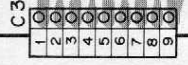
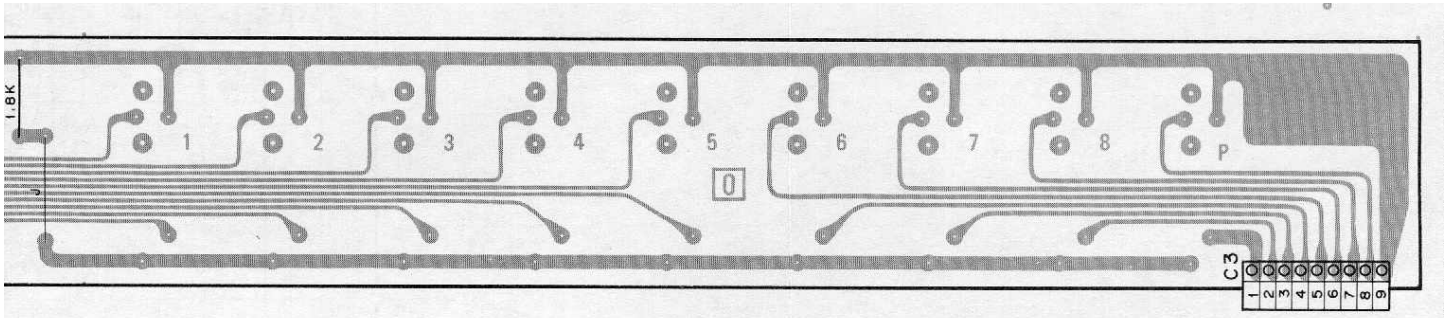

View from the printed pattern side of the circuit board

Note)  
 1. Circuit Board : LC80514



FA Cir

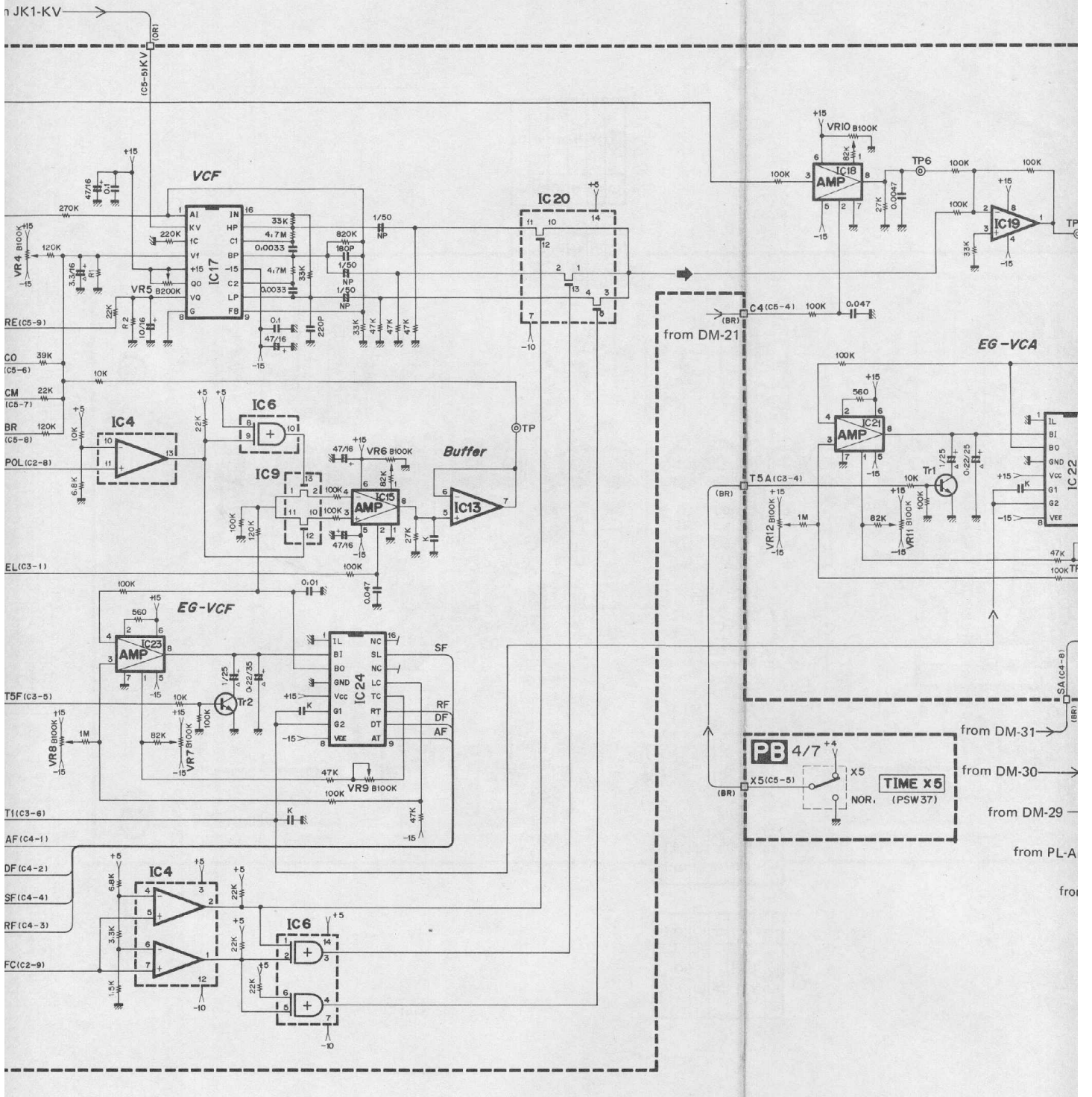

# FA Circuit Diagram

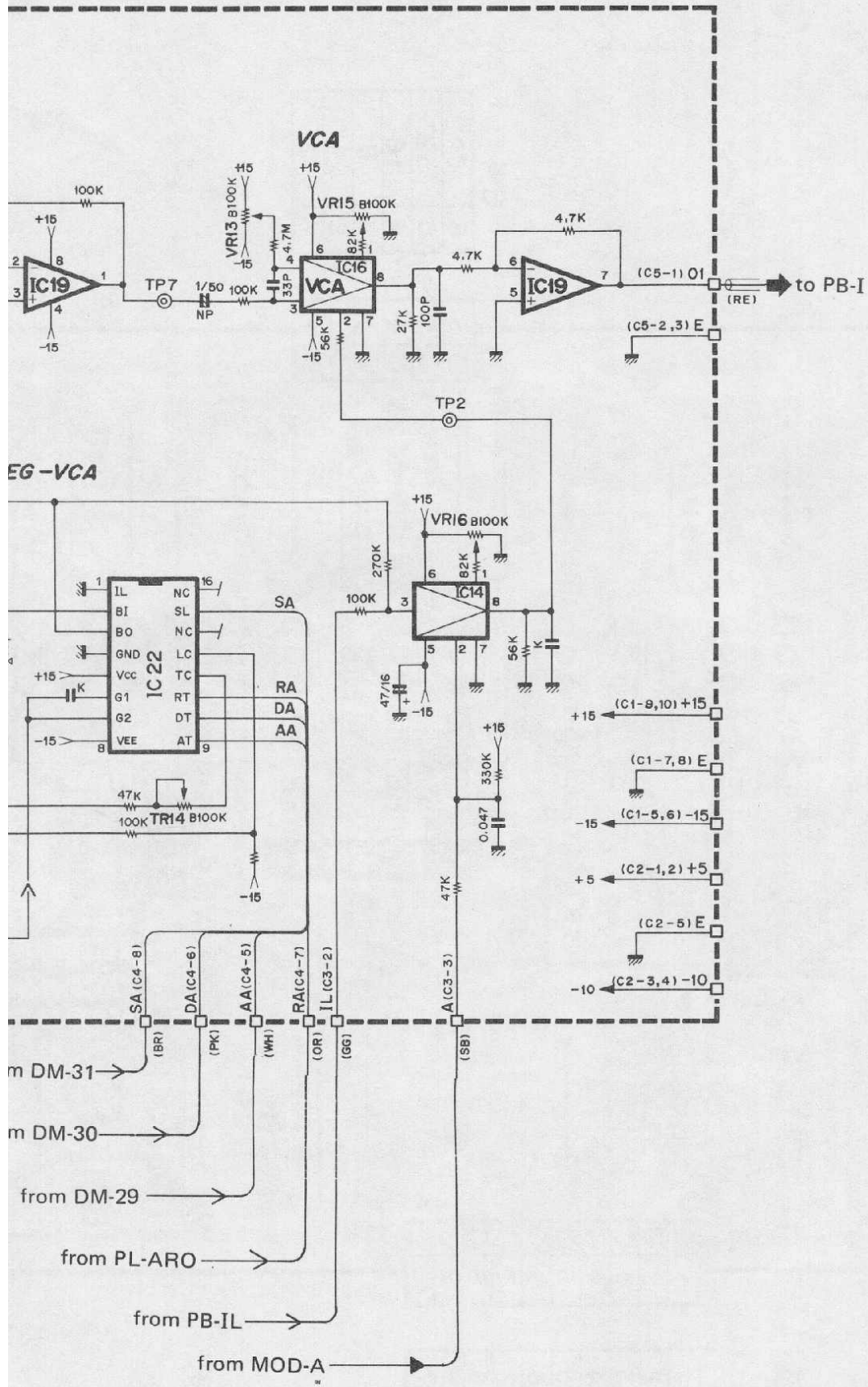

C1

S11	1
P1	2
S12	3
P2	4
-15	5
E	6
F	7
+15	8
+15	9
	10

C2

+	5	1
+	5	2
-	10	3
-	10	4
E		5
H B2		6
POL		7
F		8
C		9

C6

5	C2
4	C1
3	C3
2	E
1	NI

C5

9	RE
8	BR
7	CM
6	CO
5	KV
4	C4
3	E
2	E
1	O1

C3

1	EL
2	LL
3	A
4	T5A
5	T5F
6	T1

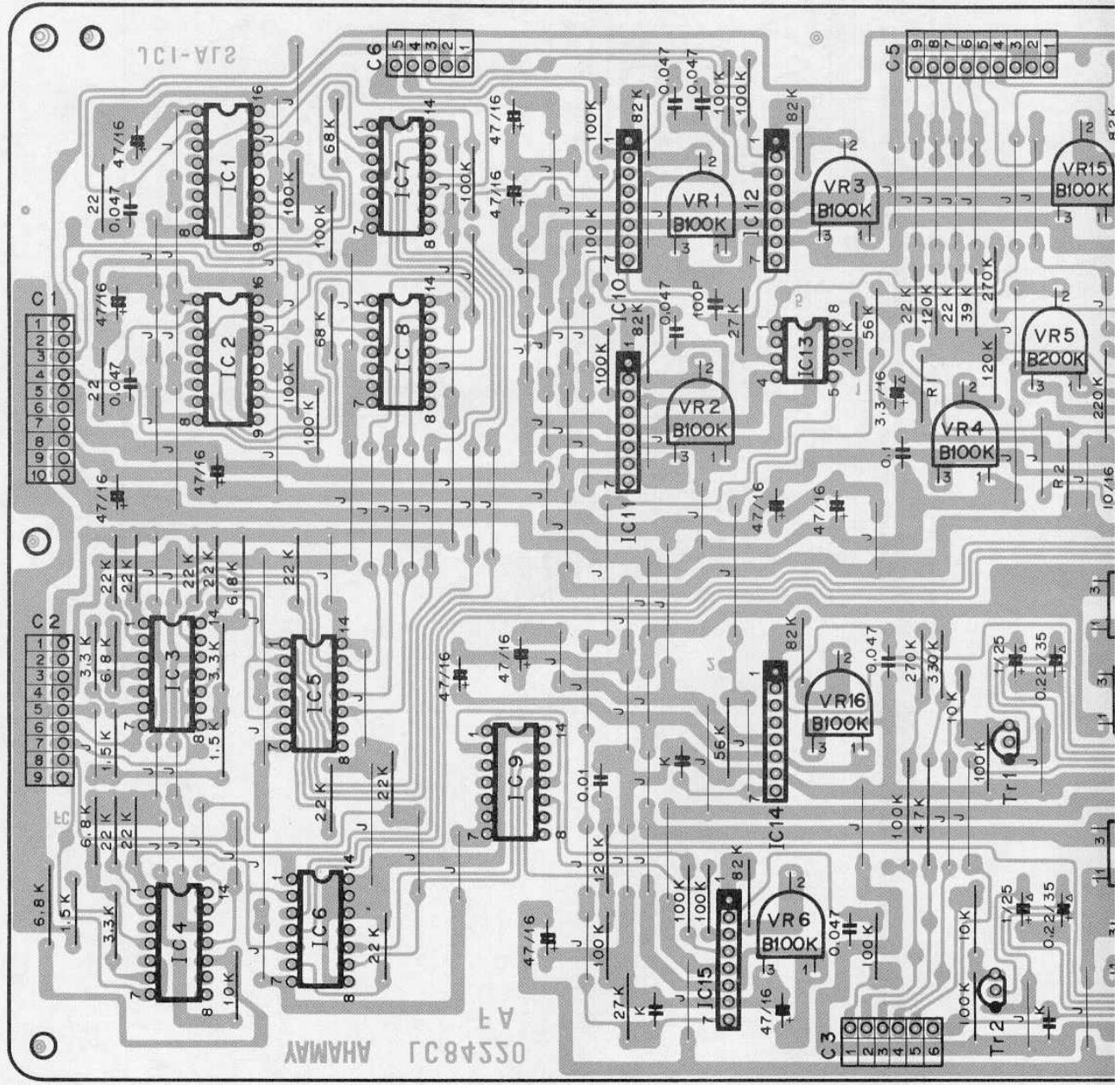

C6

5	C2
4	C1
3	C3
2	E
1	NI

C5

9	RE
8	BR
7	CM
6	CO
5	KV
4	C4
3	E
2	E
1	O1

C3

1	EL
2	LL
3	A
4	T5A
5	T5F
6	T1



# FA Circuit Board & Wiring

## C1

Pin No.	Pin Name	Wire Color	Destination
1	SI1	BR	VCO-01 (C2-7)
2	P1	SB	MOD-PO1 (C4-7)
3	SI2	RE	VCO-02 (C1-10)
4	P2	GG	MOD-PO2 (C4-4)
5	-15	YE	DC -15 (C2-6)
6	-15	YE	MOD-15 (C3-9)
7	E	BL	DC-DE (C3-9)
8	E	BL	MOD-E (C3-8)
9	+15	BR	DC+15 (C2-2)
10	+15	BR	MOD+15 (C3-10)

## C2

Pin No.	Pin Name	Wire Color	Destination
1	+5	GR	MOD+5 (C1-8)
2	+5	GR	FA+5 (C4-9)
3	-10	BE	MOD-10 (C1-6)
4	-10	BE	FA-10 (C4-10)
5	E	-	-
6	HB2	PK	DM-10 (C4-9)
7	HB1	GR	DM-5 (C5-5)
8	POL	YE	DM-24 (C3-5)
9	FC	PK	DM-20 (C3-9)

## C3

Pin No.	Pin Name	Wire Color	Destination
1	EL	WH	DM-19 (C3-10)
2	IL	GG	PB-IL (C3-9)
3	A	SB	MOD-A (C4-1)
4	T5A	BR	PB-X5 (C5-5)
5	T5F	RE	PB-X5 (C8-6)
6	T1	GR	PA-LT (C7-3)

## C4

Pin No.	Pin Name	Wire Color	Destination
1	AF	GR	DM-25 (C3-4)
2	DF	BE	DM-26 (C3-3)
3	RF	YE	PL-FRO (C1-8)
4	SF	VI	DM-27 (C3-2)
5	AA	WH	DM-29 (C2-7)
6	DA	PK	DM-30 (C2-6)
7	RA	OR	PL-ARO (C1-9)
8	SA	BR	DM-31 (C2-5)
9	+5	GR	FA+5 (C2-2)
10	-10	BE	FA-10 (C2-4)

## C5

Pin No.	Pin Name	Wire Color	Destination
1	O1	SRE	PB-I (C3-10)
2	E	SRES	
3	E	BL	PB-E (C4-8)
4	C4	BR	DM-21 (C3-8)
5	KV	OR	JK1-KV (C2-2)
6	CO	GR	DM-15 (C4-4)
7	CM	YE	MOD-F (C4-2)
8	BR	BE	PL-BR (C2-5)
9	RE	VI	DM-17 (C4-2)

## C6

Pin No.	Pin Name	Wire Color	Destination
1	NI	SWH	PA-WN (C1-3)
2	E	SWHS	
3	C3	YE	DM-14 (C4-5)
4	C1	RE	DM-12 (C4-7)
5	C2	OR	DM-13 (C4-6)

### Note)

1. Circuit Board : LC84221

2. IC

IC1, 2 : iG00158

IC3, 4 : NJM2901

IC5, 6 : TC4030BP

IC7, 8, 9, 20 : TC4016BP

IC10, 11, 12, 14,  
15, 16, 18, 21, : iG00151

23

IC13, 19 : NJM4558DV

IC17 : iG00156

IC22, 24 : iG00159

3. Transistor

Tr1, 2 : 2SC1815

4. Capacitor

△ marked : Tantalum Capacitor

K marked : Ceramic Capacitor 1000P

5. The values of R1 and R2 depend on the rank of IC17 (iG00156) as follows.

Rank	R1	R2
A	2.2K	470
B	2 K	430
C	1.8K	390

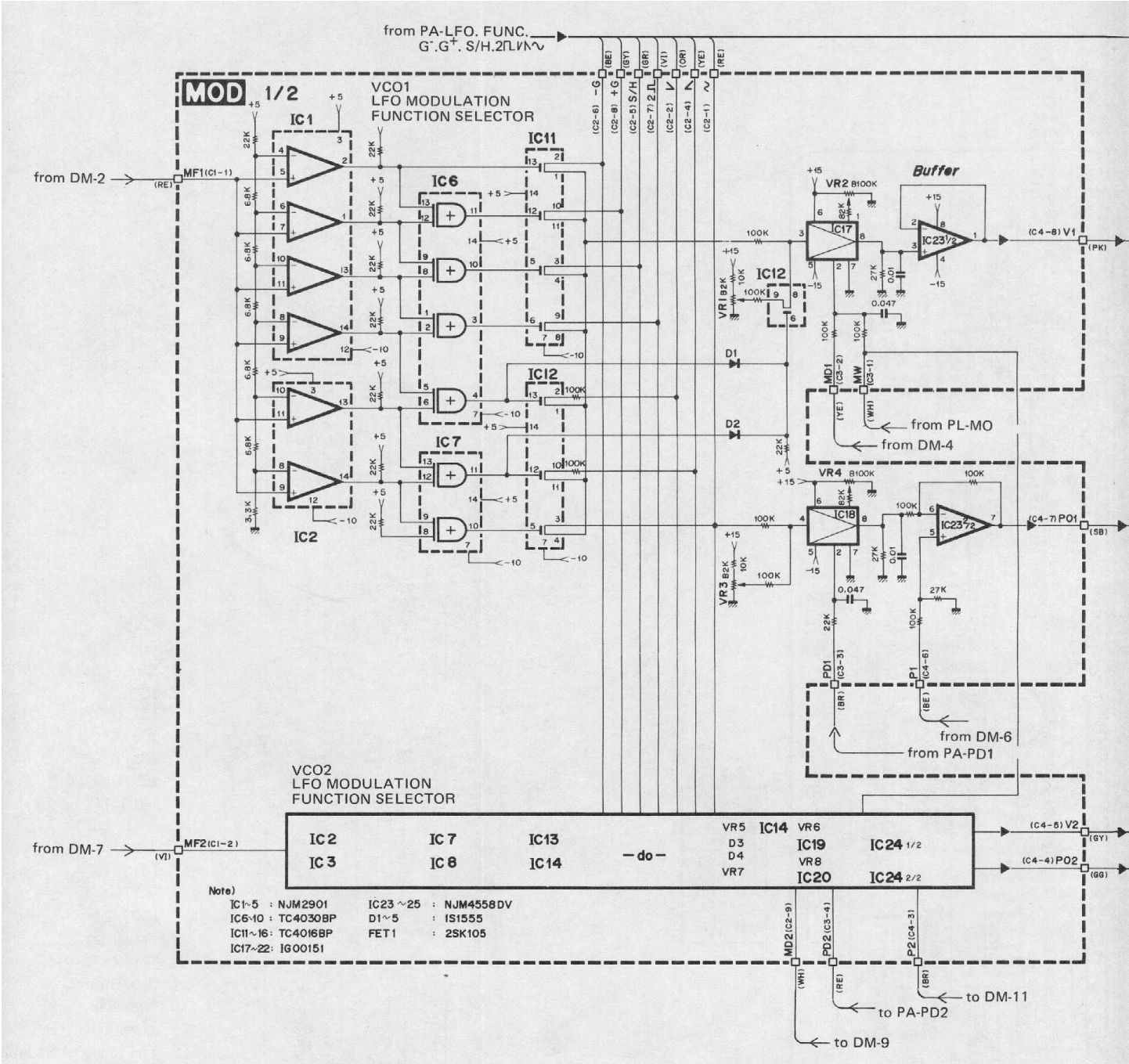

# MOD Circuit Diagram

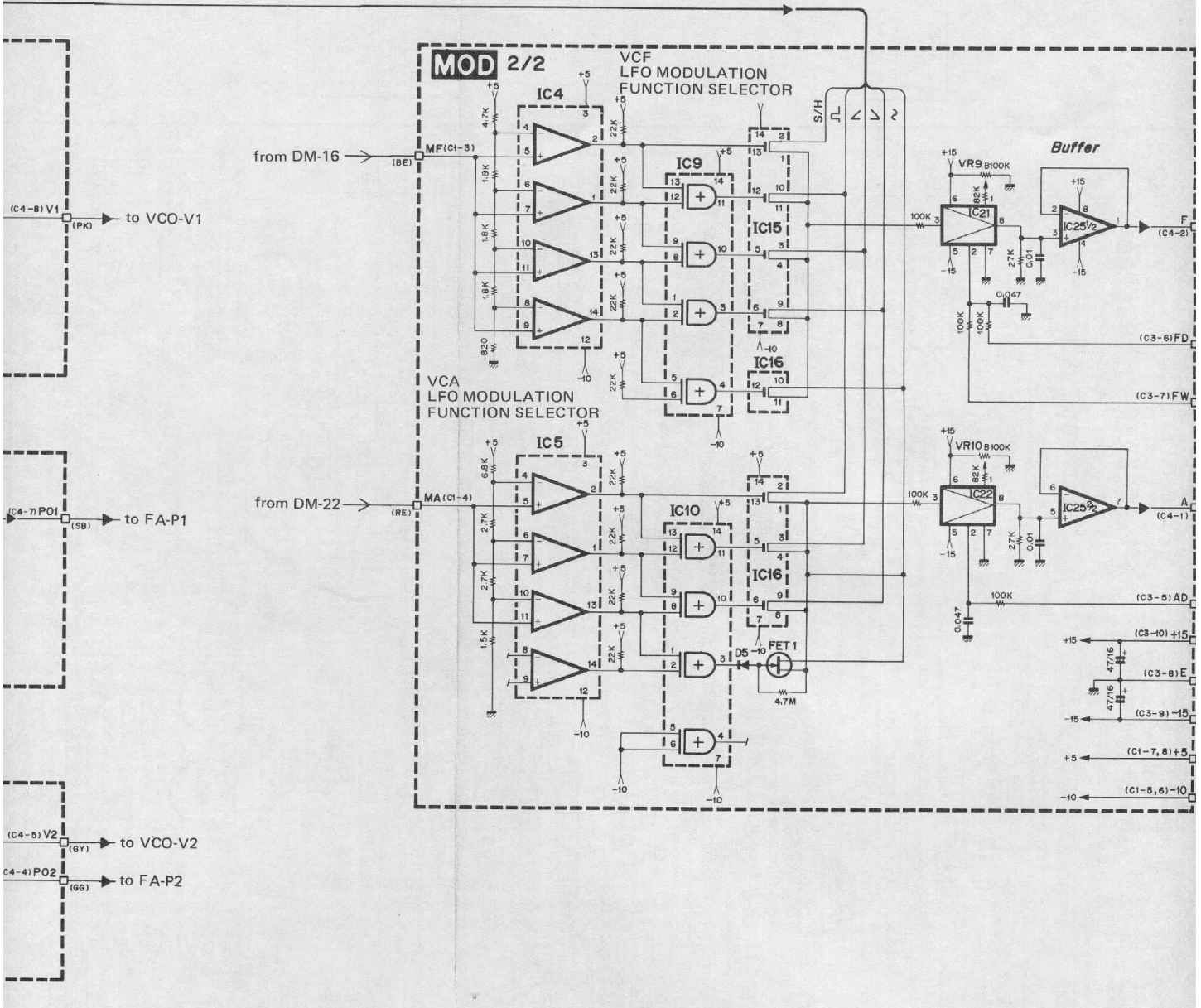

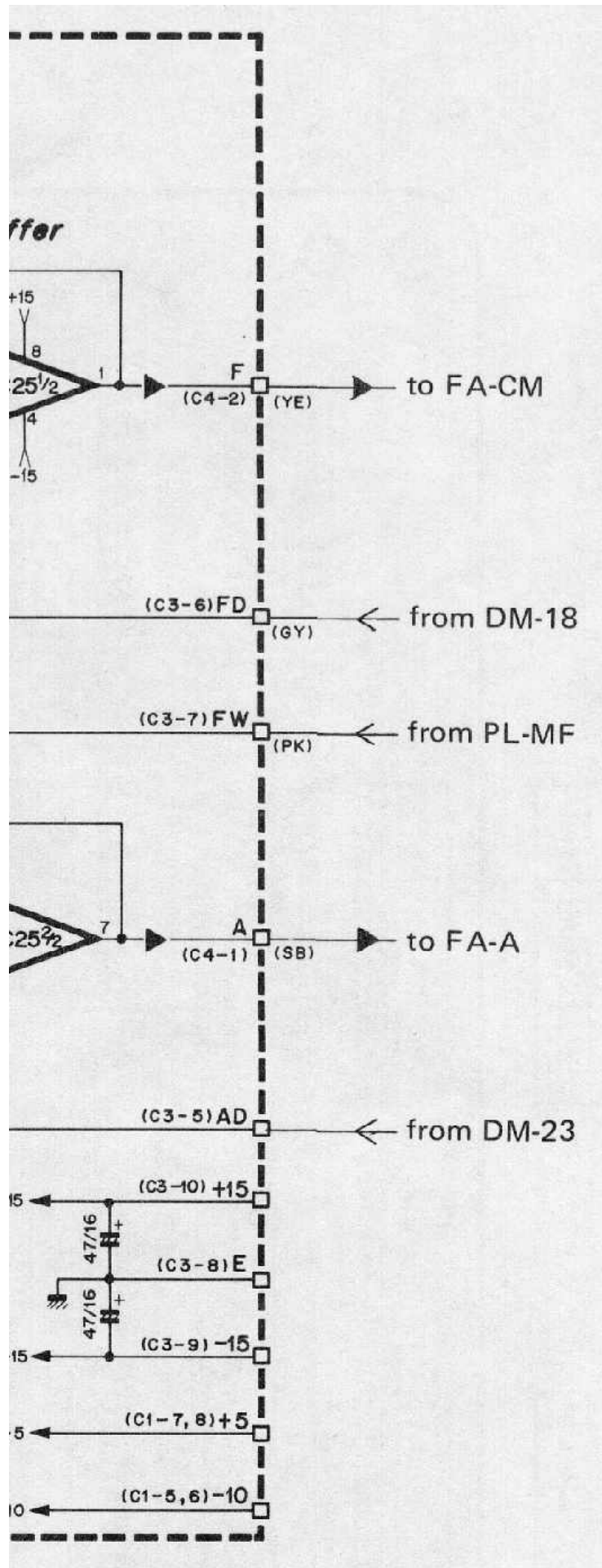

WOD



C1	1	MF1
	2	MF2
	3	MF
	4	MA
	5	-10
	6	-10
	7	+5
	8	+5

C2	1	V
	2	V
	3	FL
	4	L
	5	S/H
	6	G-
	7	2FL
	8	G+
	9	MD2

C3	1	MW
	2	MD1
	3	PD1
	4	PD2
	5	AD
	6	FD
	7	FW
	8	E
	9	-15
	10	+15

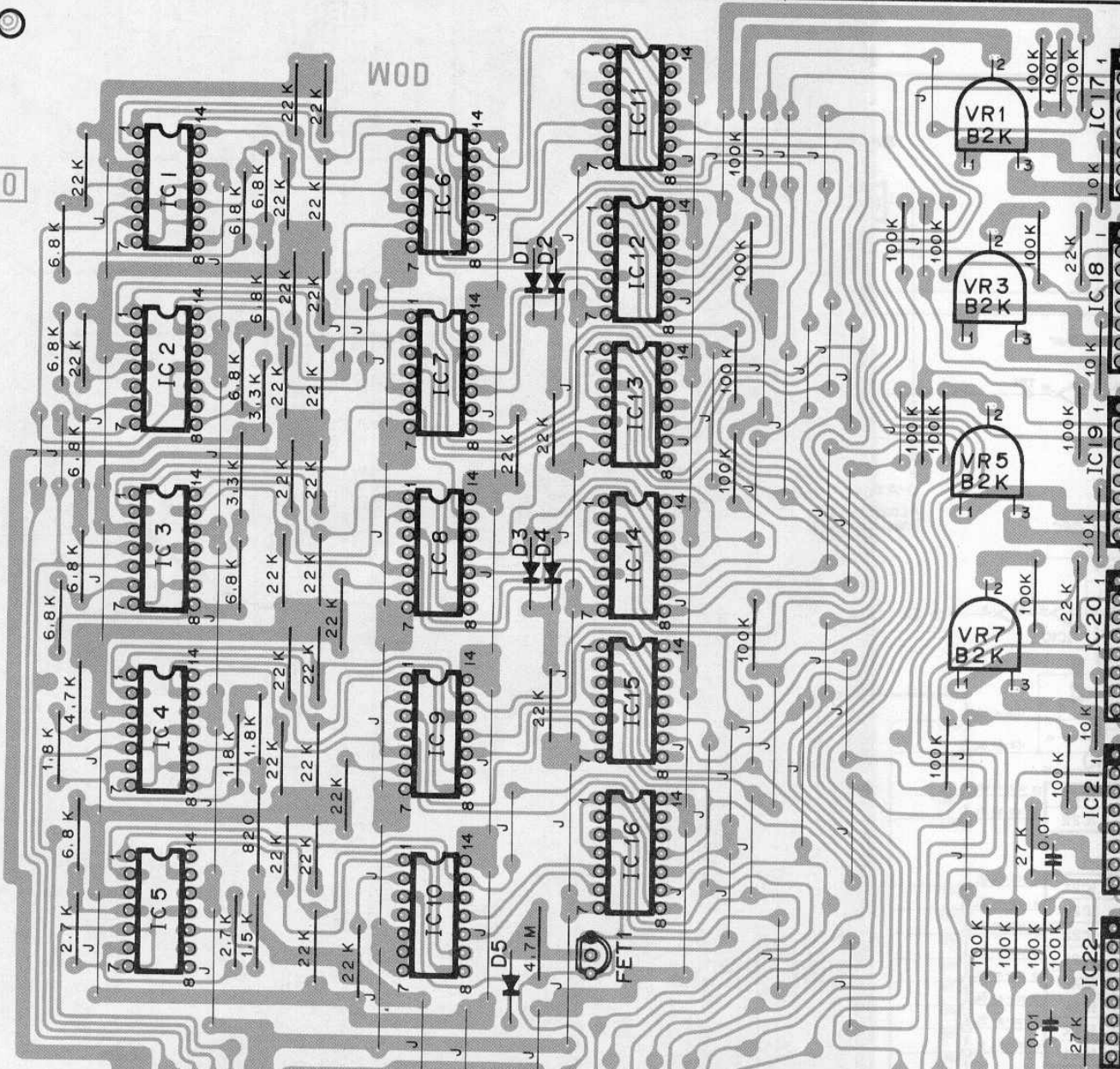

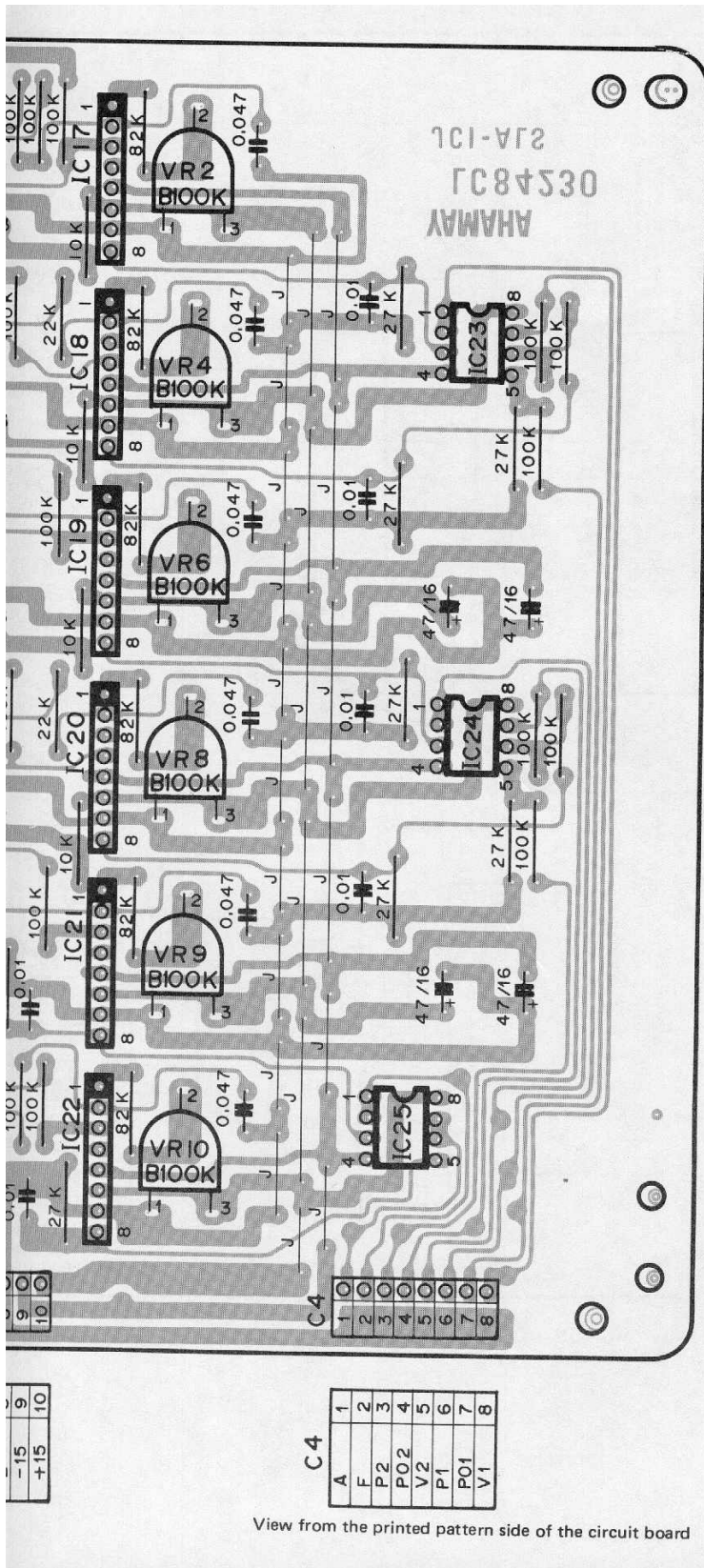

View from the printed pattern side of the circuit board

C1

Pin No.	Pin Name	Wire Color	Destination
1	MF1	RE	DM-2 (C5-8)
2	MF2	VI	DM-7 (C5-3)
3	MF	BE	DM-16 (C4-3)
4	MA	RE	DM-22 (C3-7)
5	-10	BE	DC-10 (C3-10)
6	-10	BE	FA-10 (C2-3)
7	+5	GR	DC-15 (C3-7)
8	+5	GR	FA-15 (C2-1)

C2

Pin No.	Pin Name	Wire Color	Destination
1	~	RE	PA-~ (C6-2)
2	✓	OR	PA-✓ (C6-4)
3	∩	WH	PA-∩ (C1-5)
4	∪	YE	PA-∪ (C6-3)
5	S/H	GR	PA-S/H (C1-4)
6	G <sup>+</sup>	BE	PA-G <sup>+</sup> (C1-2)
7	2 ∩	VI	PA-2 ∩ (C1-6)
8	G <sup>+</sup>	GY	PA-G <sup>+</sup> (C1-1)
9	MD2	WH	DM-9 (C5-1)

C3

Pin No.	Pin Name	Wire Color	Destination
1	MW	WH	PL-MO (C2-7)
2	MD1	YE	DM-4 (C5-6)
3	PD1	BR	PA-PD1 (C3-4)
4	PD2	RE	PA-PD2 (C5-3)
5	AD	OR	DM-23 (C3-6)
6	FD	GY	DM-18 (C4-1)
7	FW	PK	PL-MF (C2-8)
8	E	BL	FA-E (C1-8)
9	-15	YE	FA-15 (C1-6)
10	+15	BR	FA-15 (C1-10)

C4

Pin No.	Pin Name	Wire Color	Destination
1	A	SB	FA-A (C3-3)
2	F	YE	FA-CM (C5-7)
3	P2	BR	DM-11 (C4-8)
4	PO2	GG	FA-P2 (C1-4)
5	V2	GY	VCO-V2 (C1-5)
6	P1	BE	DM-6 (C5-4)
7	PO1	SB	FA-P1 (C1-2)
8	V1	PK	VCO-V1 (C2-4)

Note)

- Circuit Board : LC84230
- IC
  - IC1 ~ 5 : NJM2901
  - IC6 ~ 10 : TC4030BP
  - IC11 ~ 16 : TC4016BP
  - IC17 ~ 22 : iG00151
  - IC23 ~ 25 : NJM4558DV
- Diode
  - D1 ~ 5 : 1S1555
- FET
  - FET1 : 2SK105

**PGM**

**Multiplexers**

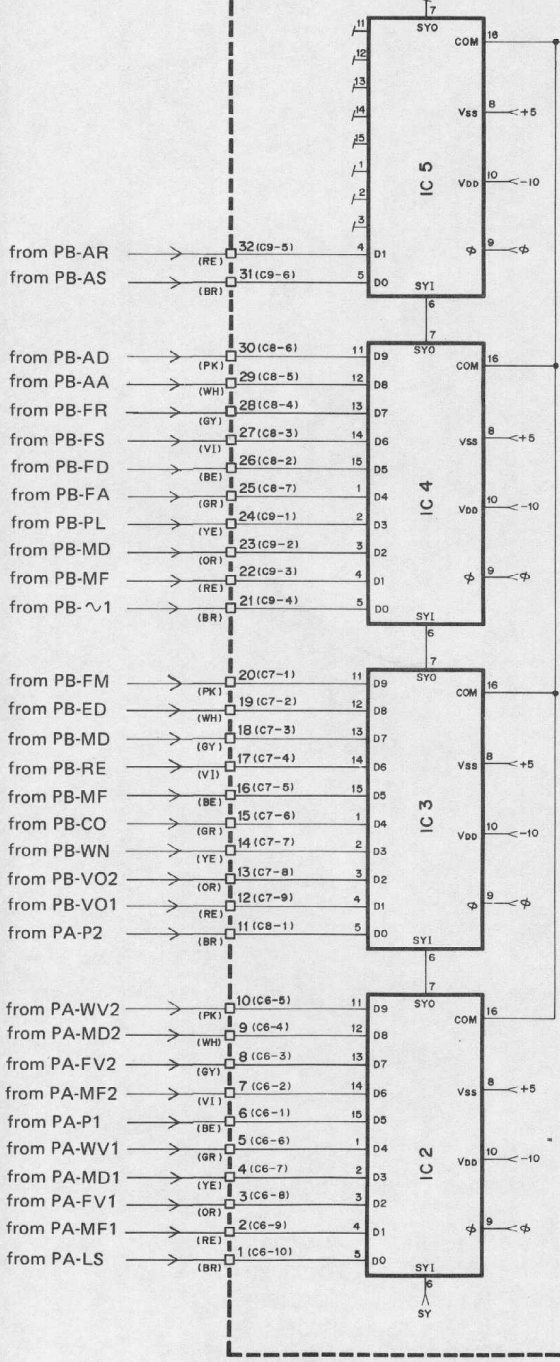

from BL-P.W.S.L. 1B ~8B

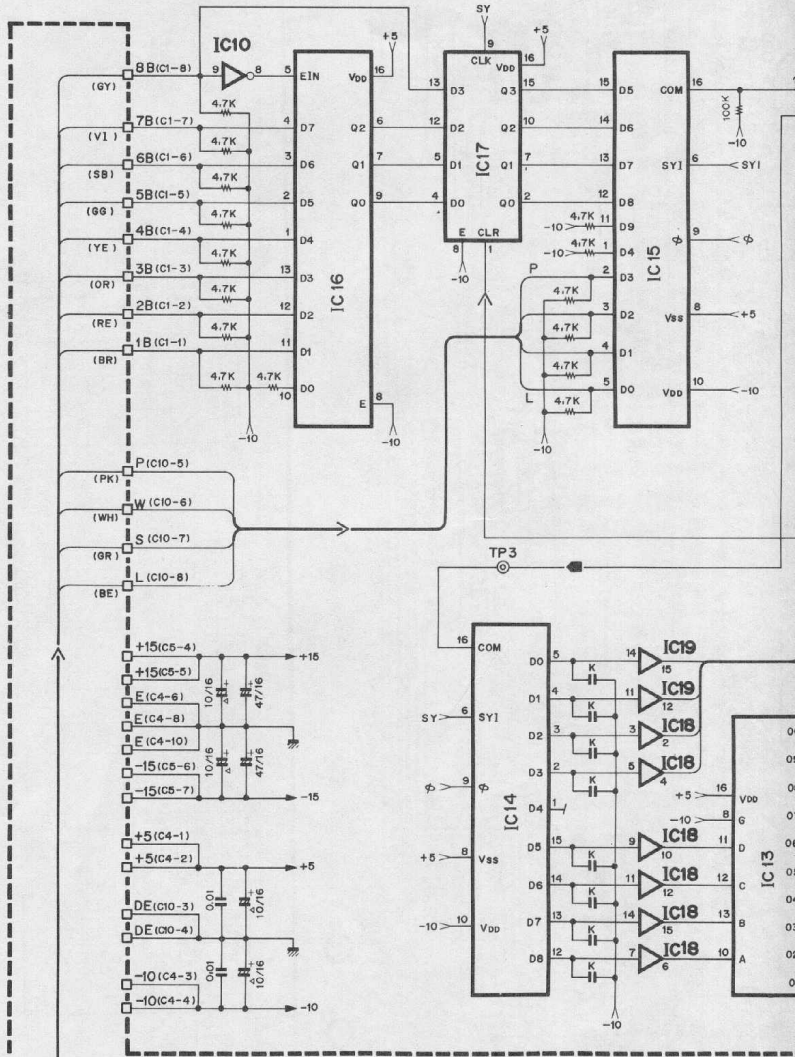

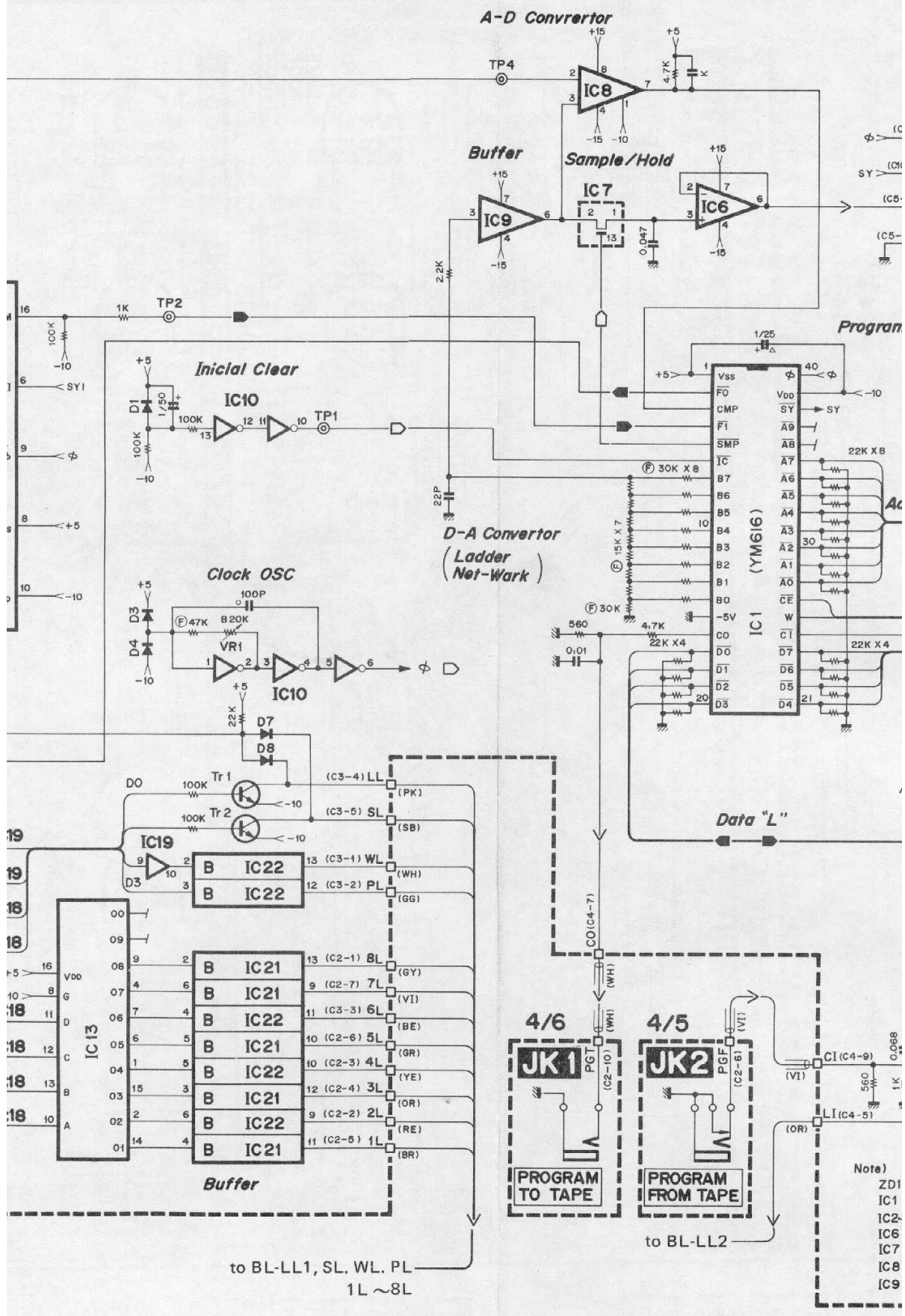

# PGM Circuit Diagram

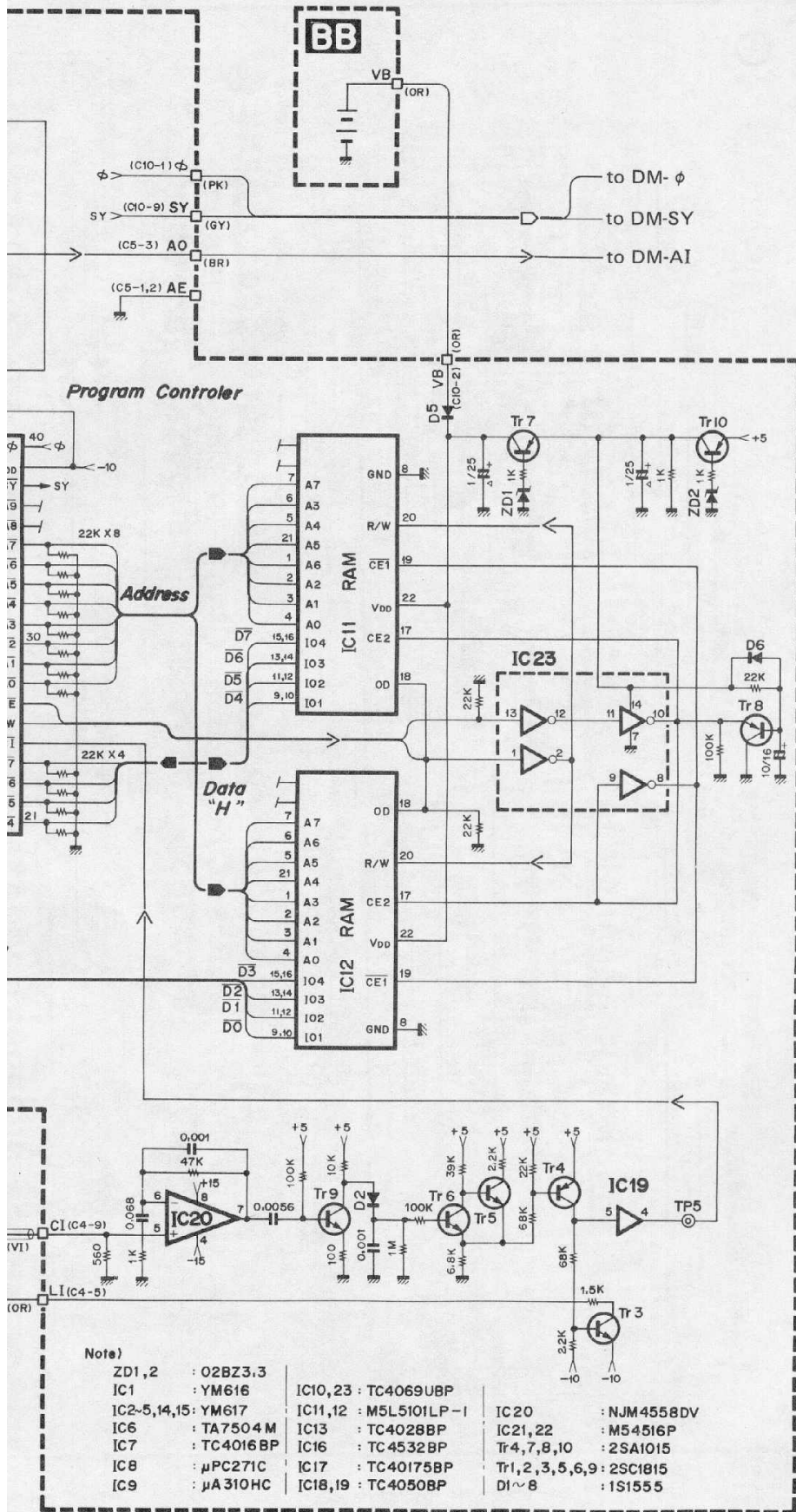

# PGM Circuit Board & Wiring

C 1

1B	1
2B	2
3B	3
4B	4
5B	5
6B	6
7B	7
8B	8

C 2

1	1
2	2
3	3
4	4
5	5
6	6
7	7

C 3

WL	1
PL	2
OL	3
LL	4
LL	5

C 4

1	1
+5	2
-10	3
-10	4
L1	5
E	6
CO	7
E	8
E	9
C1	10

C 5

AE	1
AE	2
A0	3
+15	4
+15	5
-15	6
-15	7

C 6

6	1
7	2
8	3
9	4
10	5
5	6
4	7
3	8
2	9
1	10

C 7

20	1
19	2
18	3
17	4
16	5
15	6

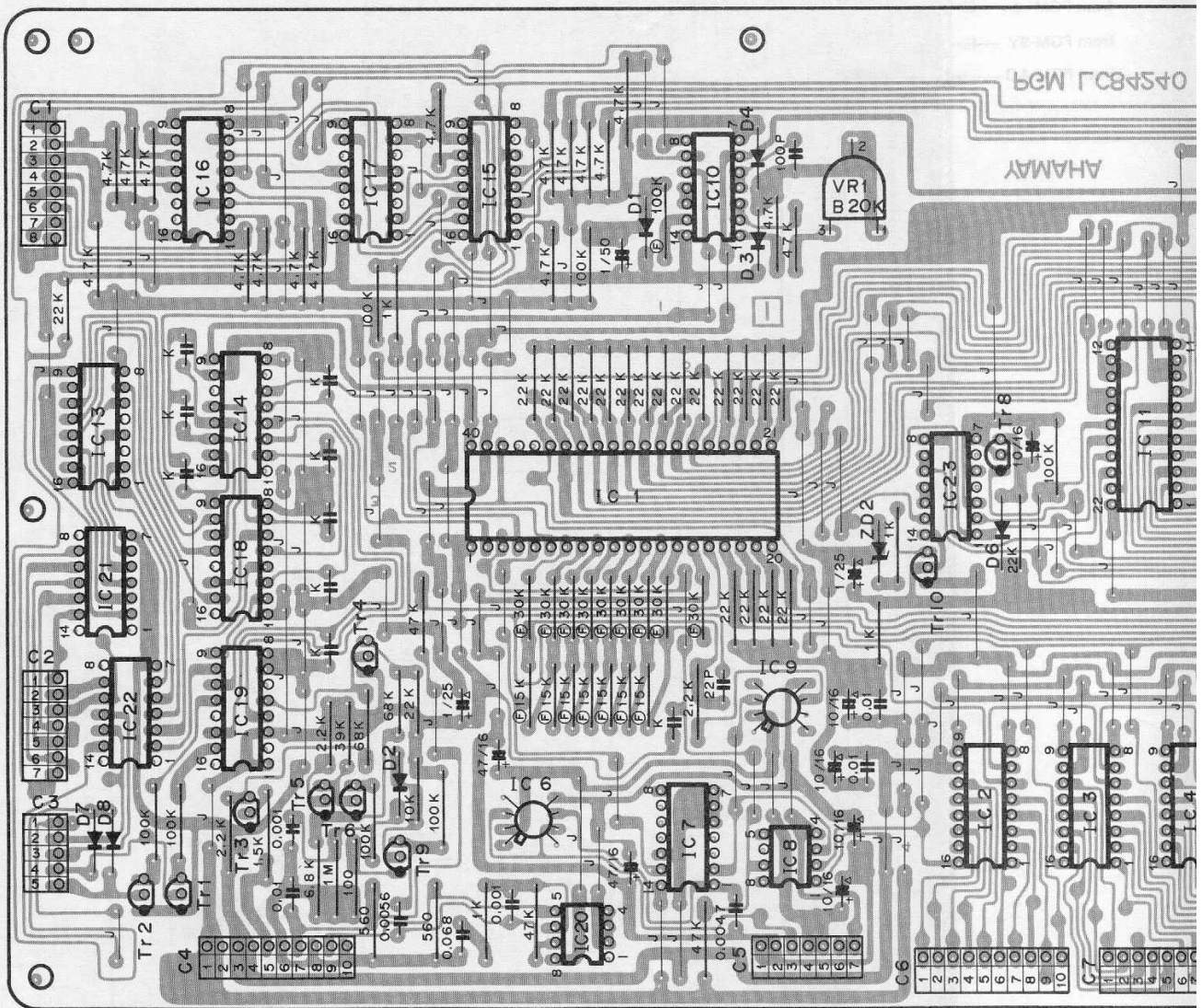

Note)

1. Circuit Board : LC84241
2. IC
 

IC1	: YM61600	IC13	: TC4028BP
IC2 ~ 5, 14,		IC16	: TC4532BP
15	: YM61700	IC17	: TC40175
IC6	: TA7504	IC18, 19	: TC4050BP
IC7	: TC4016BP	IC20	: NJM4558DV
IC8	: μPC271C	IC21, 22	: M54516P
IC9	: μA810HC		
IC10, 23	: TC4069UBP	3. Transistor	
IC11, 12	: M5L5101LP-1	Tr4, 7, 8, 10	: 2SA1015
		Tr1, 2, 3, 5,	
		6, 9	: 2SC1815
3. Diode

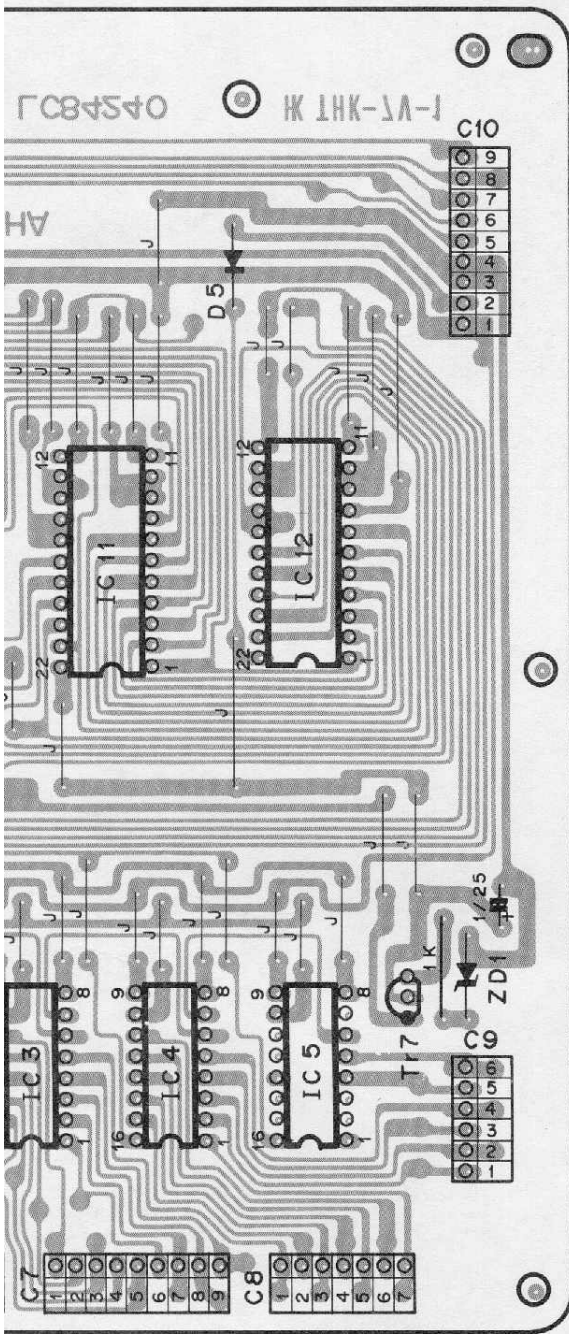

**C10**

9	SY
8	L
7	S
6	W
5	P
4	DE
3	DE
2	VB
1	φ

**C9**

6	31
5	32
4	21
3	22
2	23
1	24

**C7**

20	1
19	2
18	3
17	4
16	5
15	6
14	7
13	8
12	9

**C8**

11	1
26	2
27	3
28	4
29	5
30	6
25	7

C4028BP      D1 ~ 8      : 1S1555  
 C4532BP      ZD1, 2     : 02BZ3-3  
 C40175        5. Capacitor  
 C4050BP      △ marked    : Tantalum Capacitor  
 JJM4558DV    K marked    : Ceramic Capacitor 1000P  
 M54516P

SA1015

SC1815

**C1**

Pin No.	Pin Name	Wire Color	Destination
1	1B	BR	BL-1B (C2-1)
2	2B	RE	BL-2B (C2-2)
3	3B	OR	BL-3B (C2-3)
4	4B	YE	BL-4B (C2-4)
5	5B	GG	BL-5B (C2-5)
6	6B	SB	BL-6B (C3-5)
7	7B	VI	BL-7B (C3-6)
8	8B	GY	BL-8B (C3-7)

**C6**

Pin No.	Pin Name	Wire Color	Destination
1	6	BE	PA-P1 (C3-5)
2	7	VI	PA-MF2 (C4-7)
3	8	GY	PA-FV2 (C5-2)
4	9	WH	PA-MD2 (C5-1)
5	10	PK	PA-WV2 (C5-5)
6	5	GR	PA-WV1 (C3-6)
7	4	YE	PA-MD1 (C3-2)
8	3	OR	PA-FV1 (C3-3)
9	2	RE	PA-MF1 (C3-1)
10	1	BR	PA-LS (C2-1)

**C2**

Pin No.	Pin Name	Wire Color	Destination
1	8L	GY	BL-8L (C2-2)
2	2L	RE	BL-2L (C2-9)
3	4L	YE	BL-4L (C2-7)
4	3L	OR	BL-3L (C2-8)
5	1L	BR	BL-1L (C2-10)
6	5L	GR	BL-5L (C2-6)
7	7L	VI	BL-7L (C3-3)

**C7**

Pin No.	Pin Name	Wire Color	Destination
1	20	PK	PB-FM (C3-5)
2	19	WH	PB-ED (C2-7)
3	18	GY	PB-MD (C2-6)
4	17	VI	PB-RE (C2-5)
5	16	BE	PB-MF (C2-2)
6	15	GR	PB-CO (C2-4)
7	14	YE	PB-WN (C8-1)
8	13	OR	PB-VO2 (C2-1)
9	12	RE	PB-VO1 (C2-3)

**C3**

Pin No.	Pin Name	Wire Color	Destination
1	WL	WH	BL-WL (C2-11)
2	PL	GG	BL-PL (C3-1)
3	GL	BE	BL-6L (C3-4)
4	LL	PK	BL-LL1 (C1-2)
5	SL	SB	BL-SL (C1-1)

**C8**

Pin No.	Pin Name	Wire Color	Destination
1	11	BR	PA-P2 (C5-4)
2	26	BE	PB-FD (C8-3)
3	27	VI	PB-FS (C8-4)
4	28	GY	PB-FR (C8-5)
5	29	WH	PB-AA (C5-1)
6	30	PK	PB-AD (C5-2)
7	25	GR	PB-FA (C8-2)

**C4**

Pin No.	Pin Name	Wire Color	Destination
1	+5	GR	DC+5 (C2-7)
2	+5	GR	DM+5 (C1-2)
3	-10	BE	DC-10 (C2-10)
4	-10	BE	DM-10 (C1-5)
5	LI	OR	BL-LL2 (C1-3)
6	E	SWHS	
7	CO	SWH	JK1-PGT (C2-10)
8	E	SVIS	
9	CI	SVI	JK2-PGF (C2-6)
10	E	BL	DC-DE (C3-8)

**C9**

Pin No.	Pin Name	Wire Color	Destination
1	24	YE	PB-PL (C8-7)
2	23	OR	PB-MD (C3-8)
3	22	RE	PB-MF (C3-6)
4	21	BR	PB-1 (C3-7)
5	32	RE	PB-AR (C5-4)
6	31	BR	PB-AS (C5-3)

**C10**

Pin No.	Pin Name	Wire Color	Destination
1	φ	PK	DM-φ (C1-4)
2	VB	OR	BB-VB
3	DE	BL	DC-DE (C2-8)
4	DE	BL	BB-E
5	P	PK	BL-PB (C3-8)
6	W	WH	BL-WB (C1-6)
7	S	GR	BL-SB (C1-5)
8	L	BE	BL-LB (C1-4)
9	SY	GY	DM-SY (C1-1)

**C5**

Pin No.	Pin Name	Wire Color	Destination
1	AE	BL	DC-AE (C2-3)
2	AE	BL	DM-E (C2-3)
3	AO	BR	DM-AI (C2-1)
4	+15	BR	DC+15 (C2-1)
5	+15	BR	DM+15 (C2-2)
6	-15	YE	DC-15 (C2-5)
7	-15	YE	DM-15 (C2-4)

# DM Circuit Diagram

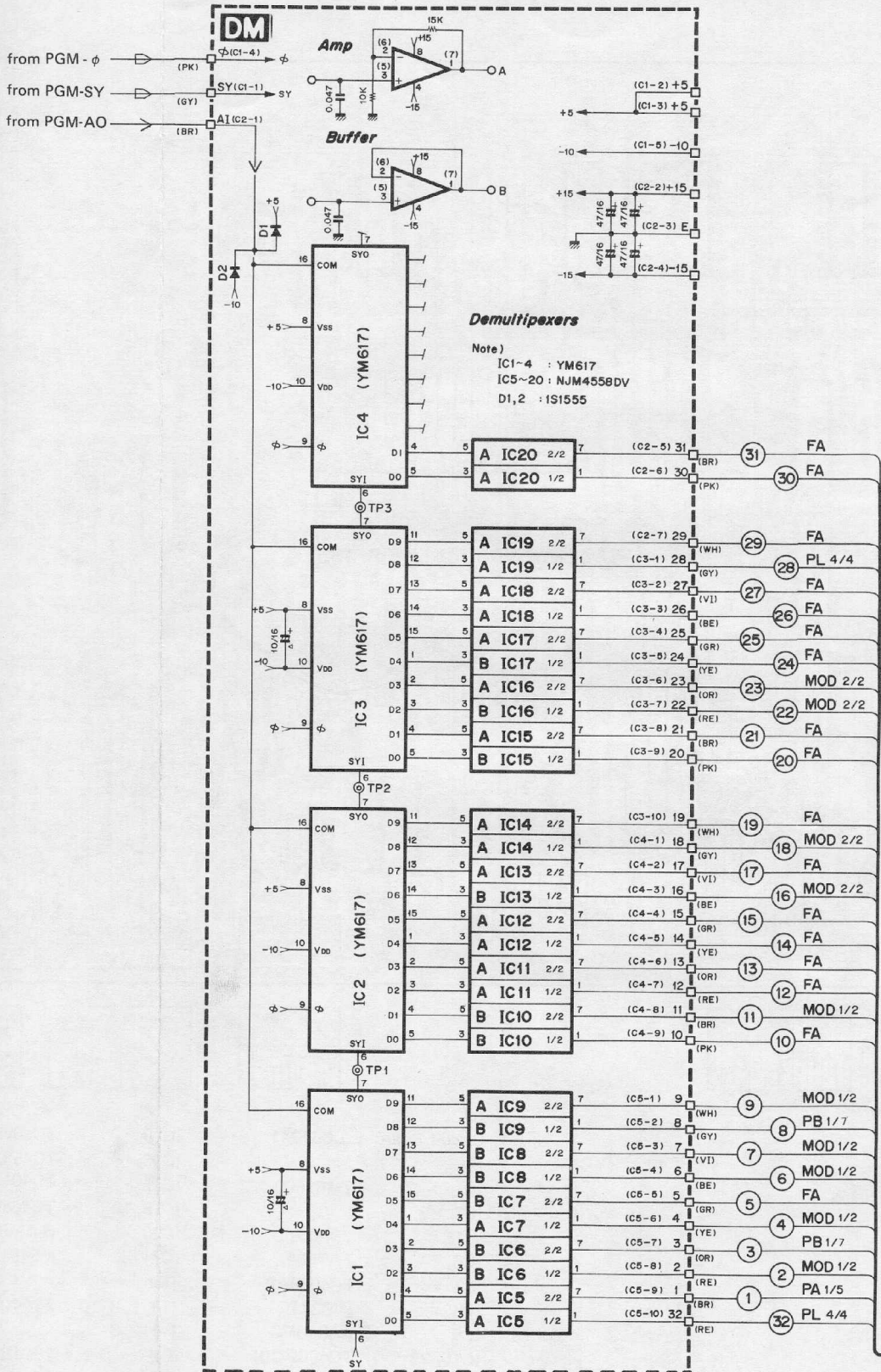

NO	BLOCK	FUNCTION
1	LFO	SPEED
2	VCO 1	MOD.FUNC
3	-do-	FEET
4	-do-	MOD. DEPTH
5	-do-	WAVE
6	-do-	PW
7	VCO 2	MOD.FUNC
8	-do-	FEET
9	-do-	MOD. DEPTH
10	-do-	WAVE
11	-do-	PW
12	MIXER	VCO 1
13	-do-	VCO 2
14	-do-	NOISE
15	VCF	CUT OFF FREQ.
16	-do-	MOD.FUNC
17	-do-	RESONANCE
18	-do-	MOD. DEPTH
19	-do-	EG DEPTH
20	-do-	HP/BP/LP
21	VCA	~1
22	-do-	MOD. FUNC
23	-do-	DEPTH
24	EG-VCF	EG/POLE
25	-do-	ATTACK TIME
26	-do-	DECAY TIME
27	-do-	SUSTAIN LEVEL
28	-do-	RELEASE TIME
29	EG-VCA	ATTACK TIME
30	-do-	DECAY TIME
31	-do-	SUSTAIN LEVEL
32	-do-	RELEASE TIME

To the same terminal No indicated on each circuit

# DM Circuit Board & Wiring

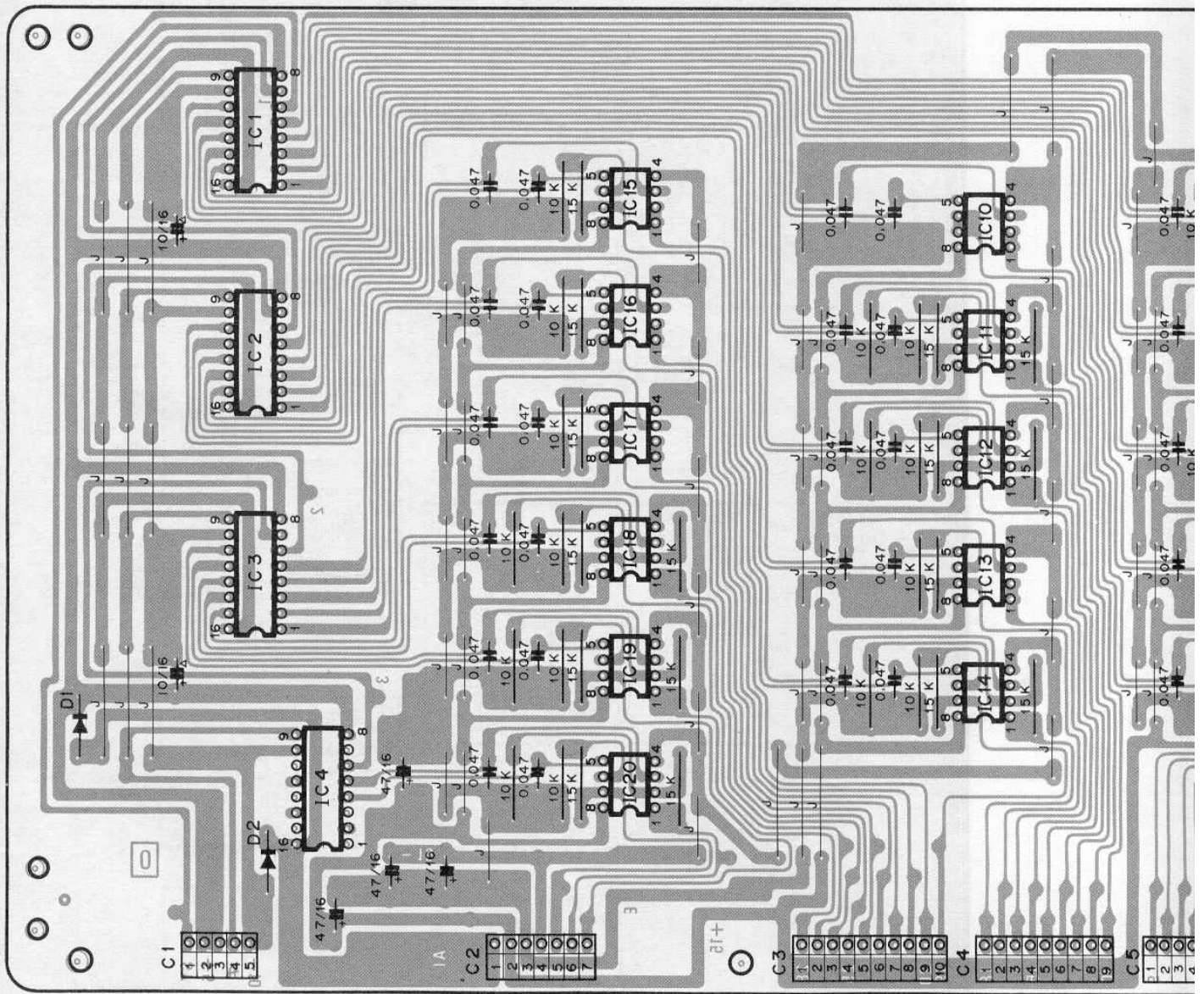

C1

SY	1
+5	2
+5	3
+5	4
-10	5

C2

A1	1
+15	2
E	3
-15	4
31	5
30	6
29	7

C3

28	1
27	2
26	3
25	4
24	5
23	6
22	7
21	8
20	9
19	10

C4

18	1
17	2
16	3
15	4
14	5
13	6
12	7
11	8
10	9

C5

9	1
8	2
7	3
6	4

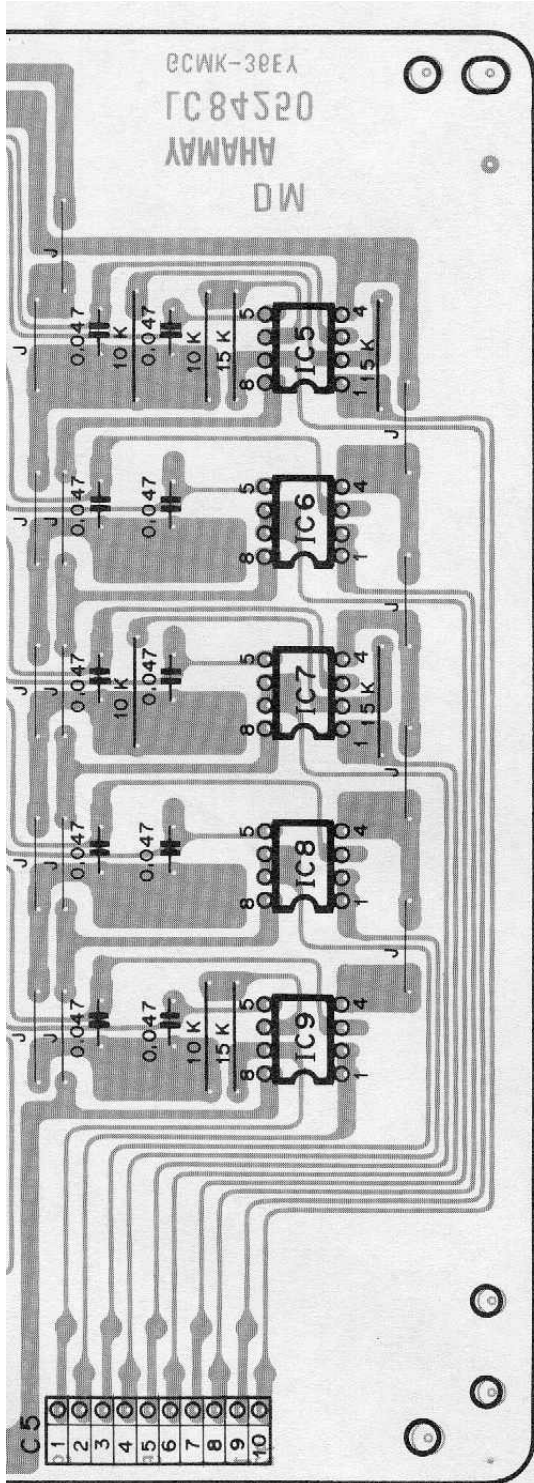

1	2	3	4	5	6	7	8	9	10
9	8	7	6	5	4	3	2	1	32

C1

Pin No.	Pin Name	Wire Color	Destination
1	SY	GY	PGM-SY (C10-9)
2	+5	GR	PGM+5 (C4-2)
3	+5	GR	BL+5 (C3-9)
4	∅	PK	PGM-∅ (C10-1)
5	-10	BE	PGM-10 (C4-4)

C2

Pin No.	Pin Name	Wire Color	Destination
1	AI	BR	PGM-AO (C5-3)
2	+15	BR	PBM+15 (C5-5)
3	E	BL	PGM-AE (C5-2)
4	-15	YE	PGM-15 (C5-7)
5	31	BR	FA-SA (C4-8)
6	30	PK	FA-DA (C4-6)
7	29	WH	FA-AA (C4-5)

C3

Pin No.	Pin Name	Wire Color	Destination
1	28	GY	PL-FPI (C1-6)
2	27	VI	FA-SF (C4-4)
3	26	BE	FA-DF (C4-2)
4	25	GR	FA-AF (C4-1)
5	24	YE	FA-POL (C2-8)
6	23	OR	MOD-AD (C3-5)
7	22	RE	MOD-MA (C1-4)
8	21	BR	FA-C4 (C5-4)
9	20	PK	FA-FC (C2-9)
10	19	WH	FA-EL (C3-1)

C4

Pin No.	Pin Name	Wire Color	Destination
1	18	GY	MOD-FD (C3-6)
2	17	VI	FA-RE (C5-9)
3	16	BE	MOD-MF (C1-3)
4	15	GR	FA-C0 (C5-6)
5	14	YE	FA-C3 (C6-3)
6	13	OR	FA-C2 (C6-5)
7	12	RE	FA-C1 (C6-4)
8	11	BR	MOD-P2 (C4-3)
9	10	PK	FA-HB2 (C2-6)

C5

Pin No.	Pin Name	Wire Color	Destination
1	9	WH	MOD-MD2 (C2-9)
2	8	GY	PB-FT2 (C1-7)
3	7	VI	MOD-MF2 (C1-2)
4	6	BE	MOD-P1 (C4-6)
5	5	GR	FA-HB1 (C2-7)
6	4	YE	MOD-MD1 (C3-2)
7	3	OR	PB-FT1 (C1-6)
8	2	RE	MOD-MF1 (C1-1)
9	1	BR	PA-S (C6-1)
10	32	RE	PL-ARI (C1-7)

Note)

1. Circuit Board : LC84250

2. IC

IC1 ~ 4 : YM61700

IC5 ~ 20 : NJM4558DV

3. Diode

D1, 2 : 1S1555

4. Capacitor

△ marked : Tantalum Capacitor

# PL Circuit Diagram

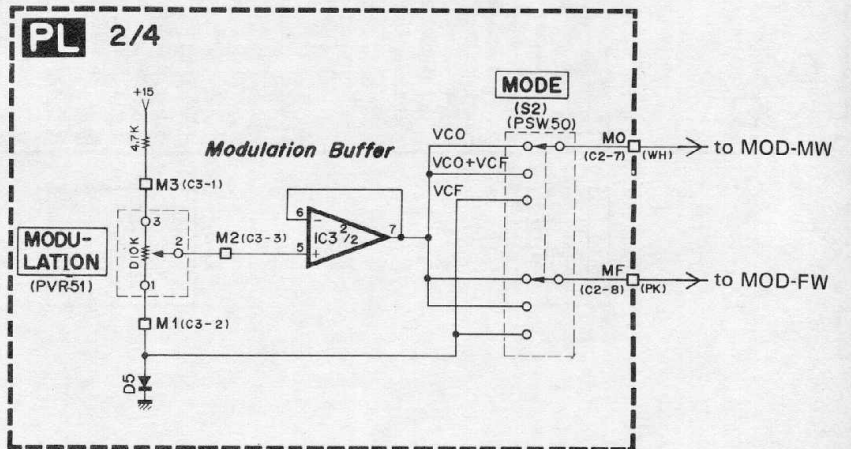
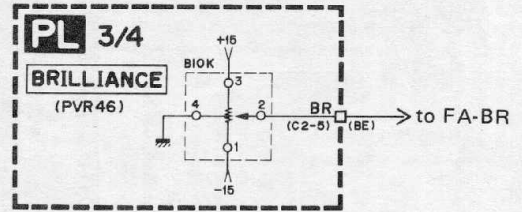
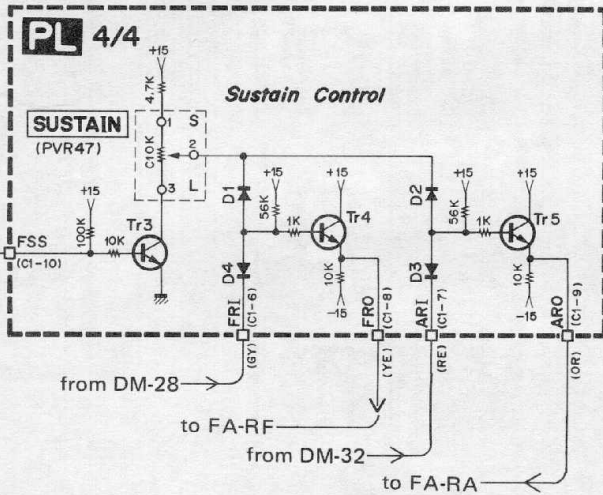
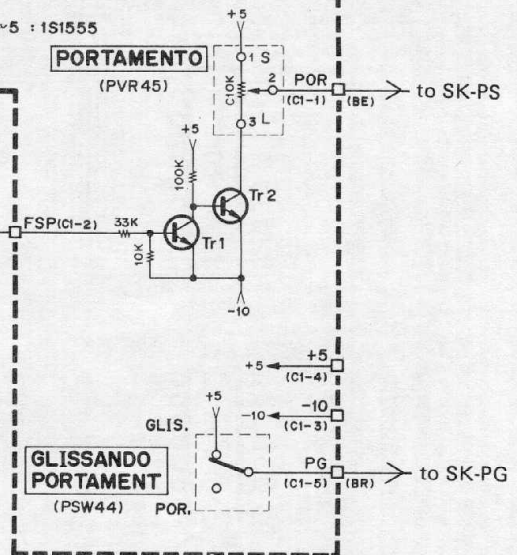
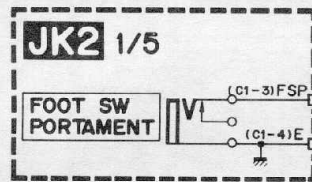
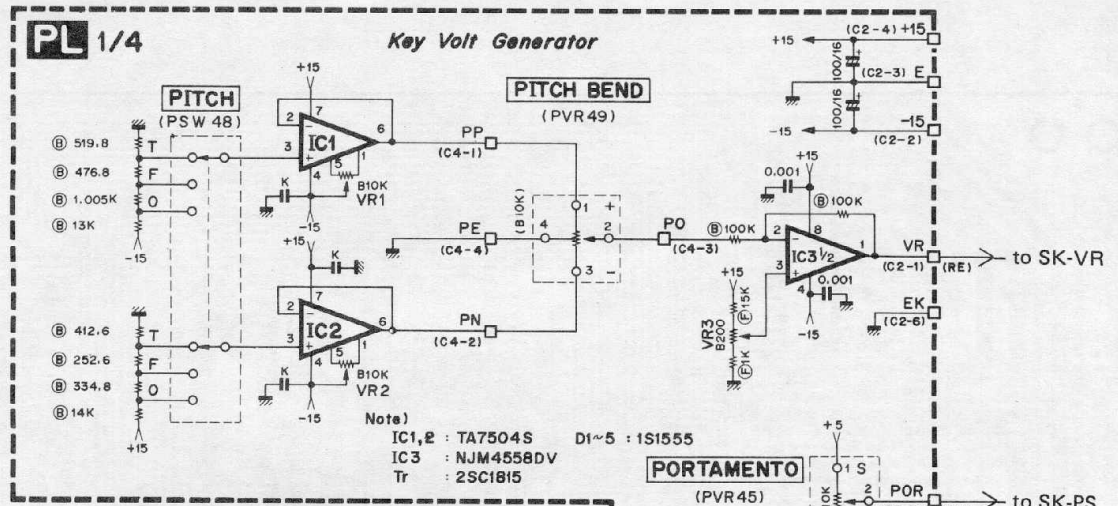

# PL Circuit Board & Wiring

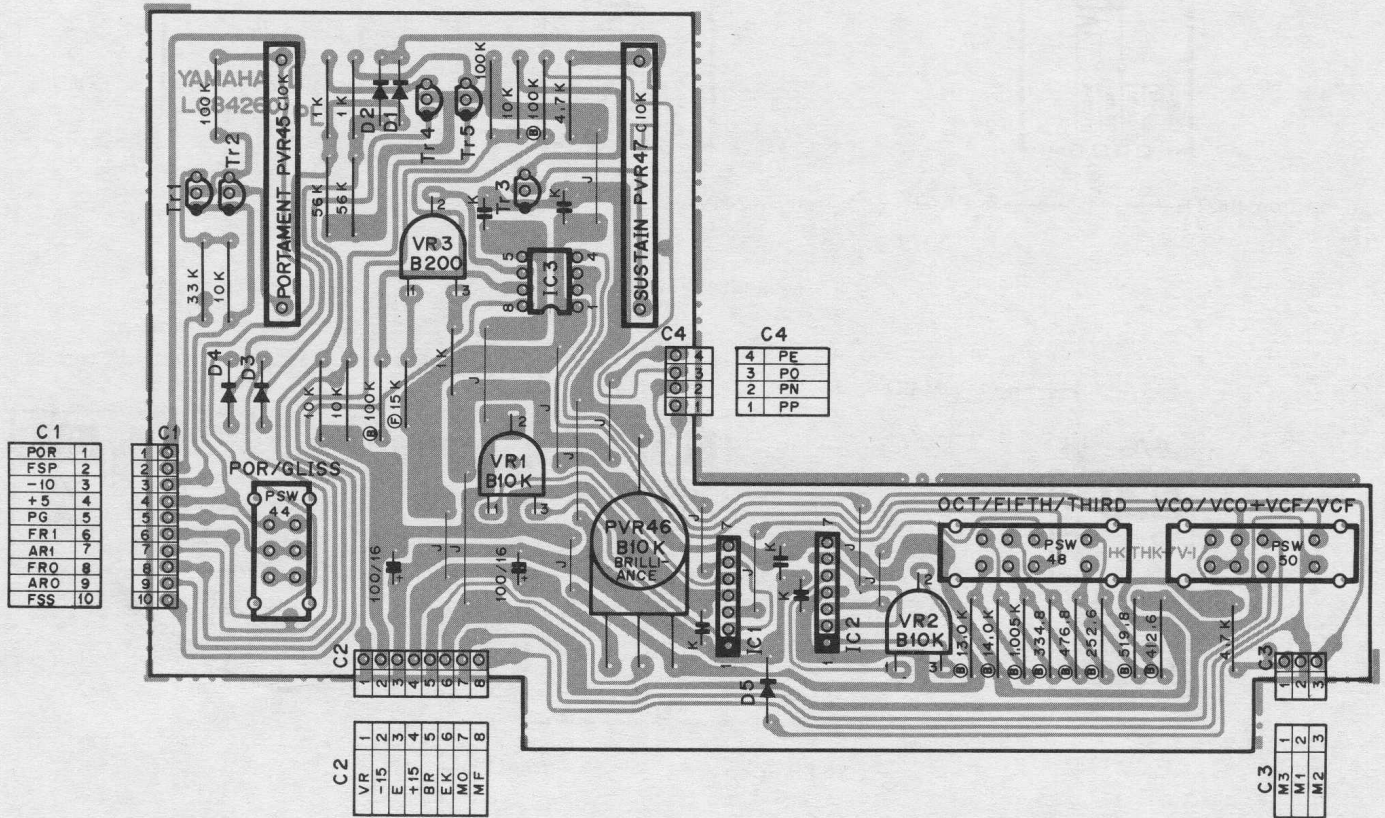

View from the printed pattern side of the circuit board

C1

Pin No.	Pin Name	Wire Color	Destination
1	POR	BE	SK-PS (C4-6)
2	FSP	GR	JK2-FSP (C1-3)
3	-10	BE	SK- -10 (C3-6)
4	+5	GR	SK+5 (C3-8)
5	PG	BR	SK-PG (C4-5)
6	FRI	GY	DM-28 (C3-1)
7	ARI	RE	DM-32 (C5-10)
8	FRO	YE	FA-RF (C4-3)
9	ARO	OR	FA-RA (C4-7)
10	FSS	VI	JK1-FSS (C1-5)

C2

Pin No.	Pin Name	Wire Color	Destination
1	VR	RE	SK-VR (C4-4)
2	-15	YE	DC- -15 (C4-6)
3	E	BL	DC-AE (C3-3)
4	+15	BR	DC+15 (C4-2)
5	BR	BE	FA-BR (C5-8)
6	EK	BL	SK-EK (C4-2)
7	MO	WH	MOD-MW (C3-1)
8	MF	PK	MOD-FW (C3-7)

C3

Pin No.	Pin Name	Wire Color	Destination
1	M3	RE	W1-3
2	M1	BL	W1-1
3	M3	BR	W1-2

C4

Pin No.	Pin Name	Wire Color	Destination
1	PP	BR	W2-1
2	PN	OR	W2-3
3	PO	RE	W2-2
4	PE	BL	W2-4

## Note)

1. Circuit Board : LC84261
2. IC  
 IC1, 2 : TA7504S  
 IC3 : NJM4558
3. Transistor  
 Tr1 ~ 5 : 2SC1815
4. Diode  
 D1 ~ 5 : 1S1555
5. Capacitor  
 K marked : 1000pF

- 5-5. Set VCO1 block output waveform to  $\square$  wave.  
 Set MIXER block output noise level to 0.  
 Adjust VCO1 until a  $\square$  wave of 3Vp-p is obtained at TP3.  
 Signal waveforms shown in Fig. 7 to 9 should be obtained at TP7 in the corresponding positions of the FILTER MODE switch.

FILTER MODE LP  
 (FC terminal voltage 0V)

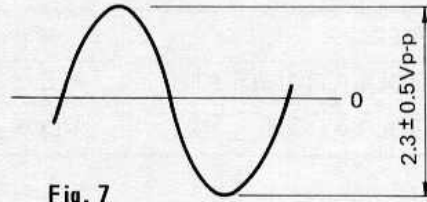

FILTER MODE BL  
 (FC terminal voltage 1.33V)

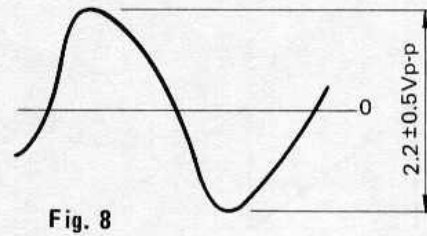

FILTER MODE HP  
 (FC terminal voltage 2.67V)

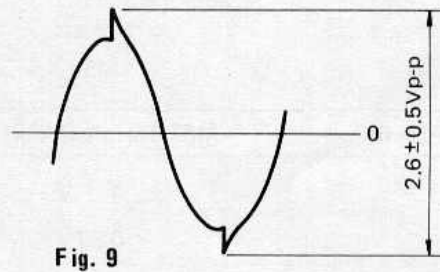

## 6. VCA

### Measuring Condition

Block	Function	Position	Terminal Voltage
VCA	INITIAL LEVEL	Adjust INITIAL LEVEL until the voltage at terminal IL is 3V.	IL 3V
EG-VCA	ATTACK TIME	S	AA 10V
	DECAY TIME	S	DA 10V
	SUSTAIN LEVEL	0	SA 0V
	RELEASE TIME	S	RA 10V

- 6-1. After the VCF circuit adjustment in paragraph 4-1 is completed, adjust VR15 until the output at terminal 01 is 0.9Vp-p.

# MOD Circuit Board

## 1. LFO Modulation Function Selector – VCO1

### Measuring Condition

Block	Function	Position	Terminal Voltage
LFO	SPEED	F	S +10V
VCO1	MODULATION DEPTH	10	MD1 +10V
EFFECT	MODULATION	VCO	MW 0V

1-1. Set VCO1 block MODULATION FUNCTION to “”.

Use VR1 to adjust bias level and VR2 to adjust signal level until the signal waveform shown in Fig. 1 is obtained at terminal V1.

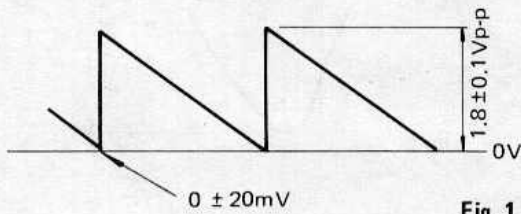







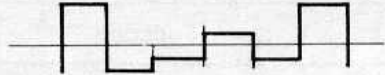



Fig. 1

Modulation Function	MFI Terminal Voltage	V1 Terminal Output
	0 V	 wave of 3.2Vp-p
	0.57V	Wave “  ” in Fig. 1
	1.14V	
	1.71V	Wave “  ” of 3.0Vp-p
S/H	2.29V	
GL <sup>+</sup>	2.86V	
GL <sup>-</sup>	3.43V	

## 2. LFO Modulation Function Selector – VC02

Do the same adjustments as above.









## 3. LFO Modulation Function Selector – VCF

Measuring Condition

Block	Function	Position	Terminal Voltage
LFO	SPEED	F	S +10V
VCF	MODULATION DEPTH	10	FD +10V
EFFECT	MODULATION	VCO	FW 0V

3-1. Set VCF block MODULATION FUNCTION to “”.

Adjust VR9 until waveform “” of  $3.5 \pm 0.2\text{Vp-p}$  is obtained at terminal F.

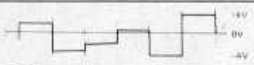







Modulation Function	MF Terminal Voltage	F Terminal Output
	0 V	$3.2 \pm 0.4\text{Vp-p}$ Waveform “  ”
	0.8V	$3.5 \pm 0.2\text{Vp-p}$ Waveform “  ”
	1.6V	” Waveform “  ”
	2.4V	$3.0 \pm 0.4\text{Vp-p}$ Waveform “  ”
S/H	3.2V	

## 4. LFO Modulation Function Selector – VCA

Block	Function	Position	Terminal Voltage
LFO	SPEED	F	S +10V
VCA	MODULATION DEPTH	10	AD +10V

4-1. Set VCA block MODULATION FUNCTION to “”.

Adjust VR10 until a  wave signal of  $2.6 \pm 0.1\text{Vp-p}$  is obtained at terminal A.

Modulation Function	MA Terminal Voltage	A Output terminal
	0V	$2.6 \pm 0.1\text{Vp-p}$ Wave “  ”
	1V	$2.85 \pm 0.3\text{Vp-p}$ Wave “  ”
	2V	$2.85 \pm 0.3\text{Vp-p}$ Wave “  ”
	3V	$2.5 \pm 0.3\text{Vp-p}$ Wave “  ”

## 5. Wave Shape Converter

Block	Function	Position	Terminal Voltage
VCO1	MODULATION FUNCTION	~	
	PWM (LFO ~)	10	PD1 +4V
	PW	50	P1 0V

- 5-1. Use VR3 to adjust bias level and VR4 to adjust signal level until the signal waveform shown in Fig. 2 is obtained at terminal PO1.
- 5-2. The output shown in Fig. 3 should be obtained at terminal PO1 when the PWM is to 0 (terminal PD1: 0V), and the PW is set to 90 (terminal P1: 4V).

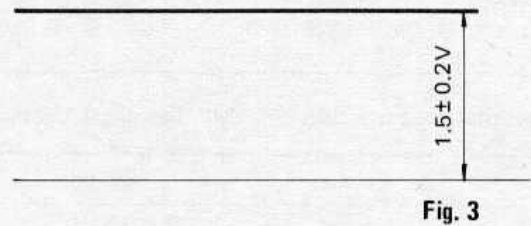
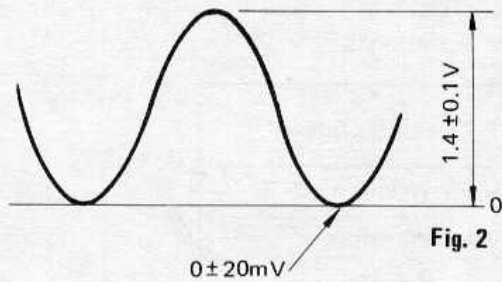

## PGM Circuit

### 1. Clock Generator

Adjust VR1 until a square wave of  $100 \pm 0.5\text{kHz}$  is obtained at terminal  $\phi$ .

### 2. Initial Clear Circuit

When the unit is powered, the signal waveform shown in Fig. 1 should be obtained at TP1.

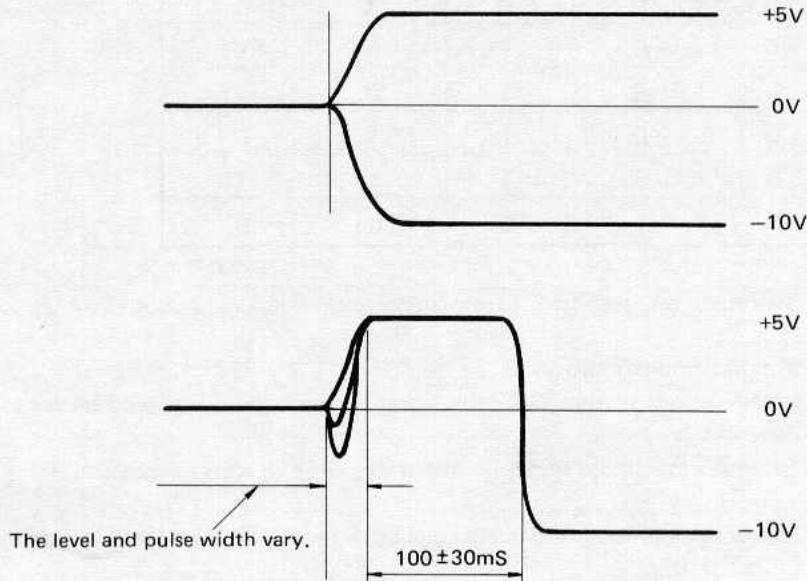

Fig. 1

### 3. Mode Selector and Mode-Display

3-1. The signal waveform shown in Fig. 1 should be obtained at TP2 and TP3 when Program Selector button "1" is pressed on. At the time, the Program Selector button "1" indicator should be on.

Even when Program Selector button "1" is released to OFF, TP3 should keep its former state with the indicator should be on.

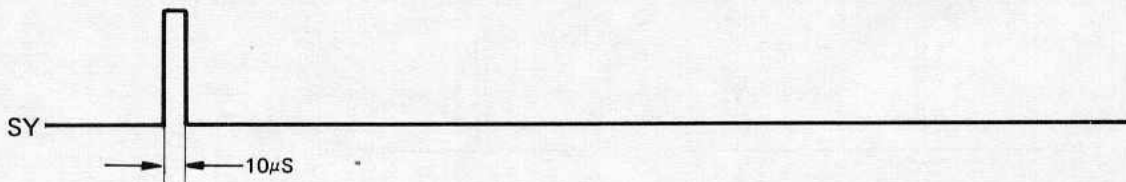
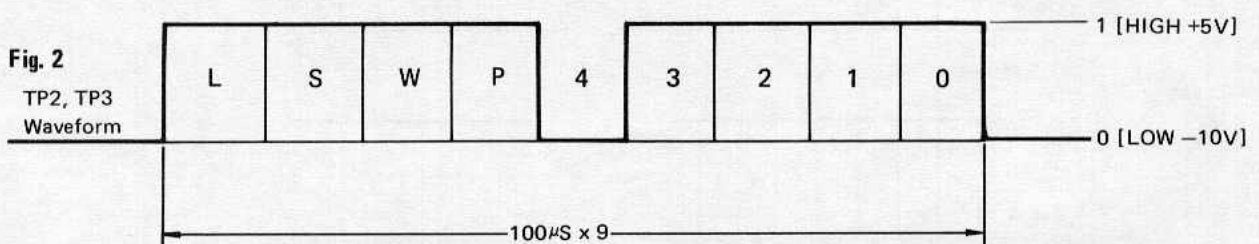

Fig. 1



3-2. When Program Selector buttons "2" to "8" are pressed on, the following logical levels should be obtained at TP2 and TP3.

Program Selector Button	4	3	2	1	0
1	0	0	0	0	1
2	0	0	0	1	0
3	0	0	0	1	1
4	0	0	1	0	0
5	0	0	1	0	1
6	0	0	1	1	0
7	0	0	1	1	1
8	0	1	0	0	0

Table 1

3-3. When the PANEL button is pressed on, section P of the signal shown in Fig. 2 should be set to "1" and be obtained at TP2 and TP3.

At the time, the PANEL button indicator should go on.

3-4. When the WRITE button is pressed on, section W of the signal shown in Fig. 2 should be set to "1" and be obtained at TP2.

At the time, TP3 and PANEL indicator should remain in the states given in above paragraph 3-3.

3-5. When a +5VDC is applied to terminal S, section S of the signal shown in Fig. 2 should be set to "1" and be obtained at TP2 and TP3.

At the time, the STORE indicator should go on. When the +5VDC is removed from terminal S, the STORE indicator remains on for 31.45 seconds, applying a +5VDC to TP1. At the time, section P of the signal shown in Fig. 2 should be set to "1" and be obtained at TP3; the PANEL indicator should go on.

3-6. When a +5VDC is applied to terminal L, section L of the signal shown in Fig. 2 should be set to "1" and be obtained at TP2. At the time, TP3 and indicators should remain in the states given in above paragraph 3-5.

#### 4. Analog Multiplexer, A/D and D/A Converters

4-1. Set LFO-SPEED to "F". (+4VDC is applied to terminal 1.) Preset each parameter so terminals 2 to 32 are all held to the ground level.

At the time, section 1 of the signal shown in Fig. 3 should be set to "H" (4V) and be obtained at TP4.

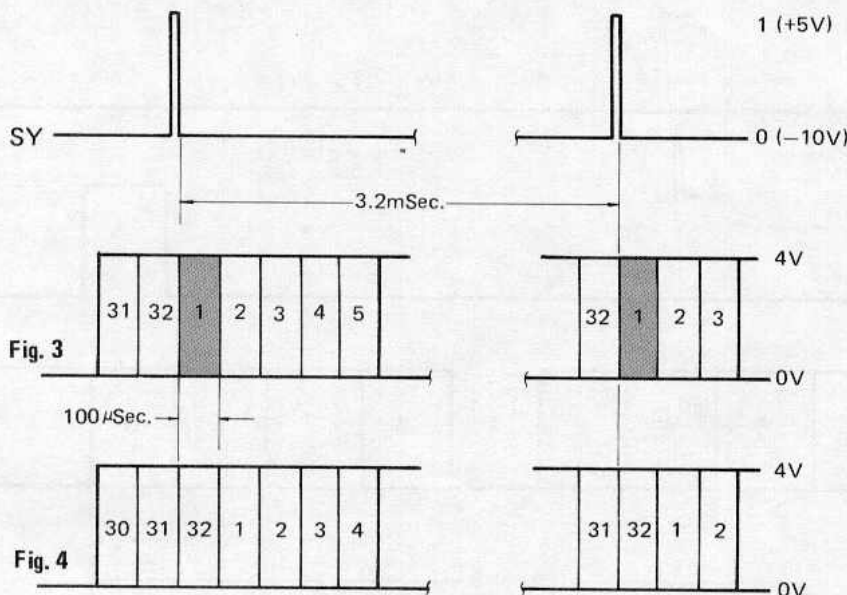

- 4-2. Do the same for other parameters.
- 4-3. The signal shown in Fig. 4, which is 100S delayed from that at TP4, should be obtained at terminal AO.
- 4.4. When the LFO-SPEED is varied (the voltage applied to terminal 1 is varied), the voltage at terminal AO should follow the voltage variation at less than 20mV step.

**DM Circuit Board**

- 1-1. Each signal shown in Fig. 1 should be obtained at TP1, TP2, and TP3.

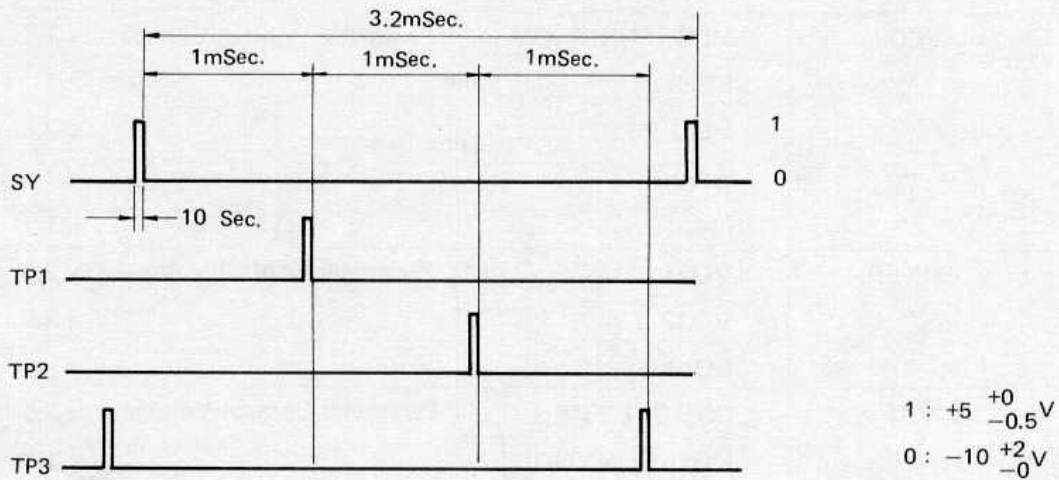

**Fig. 1**

- 1-2. The voltages listed in Table 1 should be obtained at terminals 1 to 32.

Table 1

No.	Block	Function	Output Voltage at Terminals 1 to 32 [V]	
1	LFO	SPEED	Parameter Control Voltage	x 2.5
2	VCO1	MOD. FUNCTION	↓	x 1
3	"	FEET		x 1
4	"	MOD. DEPTH		x 2.5
5	"	WAVE		x 1
6	"	PW		x 1
7	VCO2	MOD. FUNCTION		Parameter Control Voltage
8	"	FEET	↓	x 1
9	"	MOD. DEPTH		x 2.5
10	"	WAVE		x 1
11	"	PW		x 1
12	MIXER	VCO1		Parameter Control Voltage
13	"	VCO2	↓	x 2.5
14	"	NOISE		x 2.5
15	VCF	COT OFF FREQ.	Parameter Control Voltage	x 2.5
16	"	MOD. FUNCTION	↓	x 1
17	"	RESONANCE		x 2.5
18	"	MOD. DEPTH		x 2.5
19	"	EG DEPTH		x 2.5
20	"	HP/BP/LP		x 1
21	VCA	~ 1		Parameter Control Voltage
22	"	MOD. FUNCTION	↓	x 1
23	"	DEPTH		x 2.5
24	EG-VCF	EG/POLE	Parameter Control Voltage	x 1
25	"	ATTACK TIME	↓	x 2.5
26	"	DECAY TIME		x 2.5
27	"	SUSTAIN LEVEL		x 2.5
28	"	RELEASE TIME		x 2.5
29	EG-VCA	ATTACK TIME		Parameter Control Voltage
30		DECAY TIME	↓	x 2.5
31		SUSTAIN LEVEL		x 2.5
32		RELEASE TIME		x 2.5

Eg. 1. The LFO-SPEED terminal voltage is given as follows:

Parameter control voltage x 2.5 = 4 x 2.5 = 10(V)

\* The parameter control voltage for the LFO-SPEED is variable from 0 to 4V.

\* The above example shows the condition where the SPEED control is set to "F".

# DC Circuit Diagram

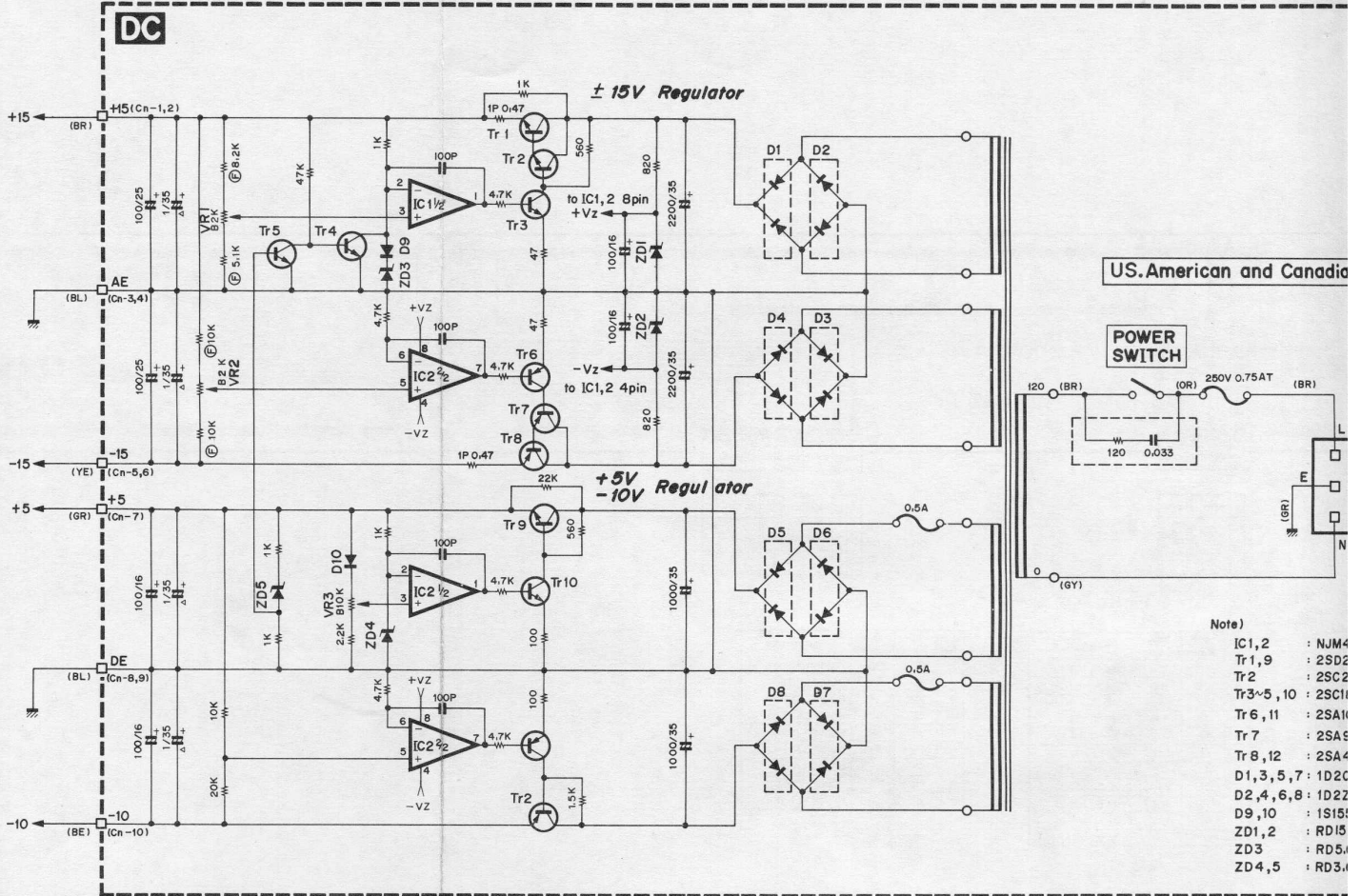

US.American and Canada

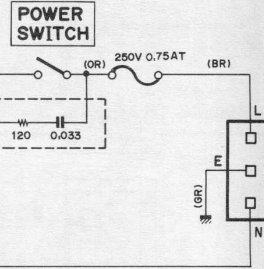

- Note)
- IC1, 2 : NJM4
  - Tr1, 9 : 2SD2
  - Tr2 : 2SC2
  - Tr3~5, 10 : 2SC11
  - Tr6, 11 : 2SA11
  - Tr7 : 2SA6
  - Tr8, 12 : 2SA4
  - D1, 3, 5, 7 : 1D2C
  - D2, 4, 6, 8 : 1D2C
  - D9, 10 : 1S15
  - ZD1, 2 : RD15
  - ZD3 : RD5.1
  - ZD4, 5 : RD3.1

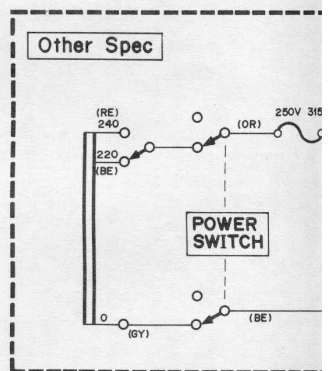
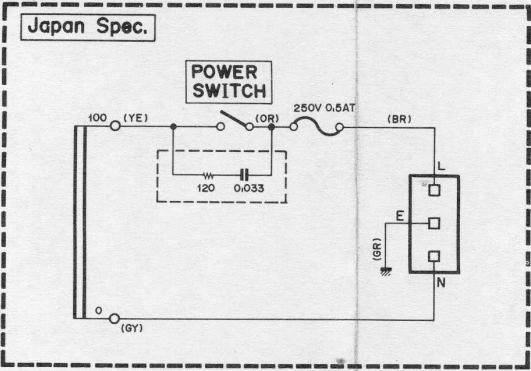

American and Canadian Spec.

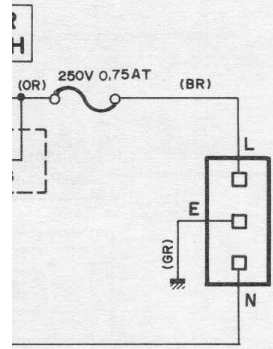

Note)

- IC1,2 : NJM4558
- Tr1,9 : 2SD235
- Tr2 : 2SC2120
- Tr3~5, 10 : 2SC1815
- Tr6, 11 : 2SA1015
- Tr7 : 2SA950
- Tr8, 12 : 2SA490
- D1, 3, 5, 7 : 1D2C1
- D2, 4, 6, 8 : 1D2Z1
- D9, 10 : 1S1555
- ZD1, 2 : RD15EB3
- ZD3 : RD5.6EB3
- ZD4, 5 : RD3.6EB1

9C

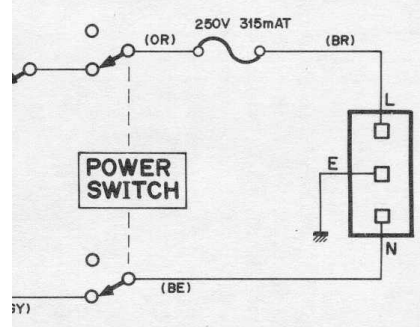

C1~C4
10 -10
9 DE
8 DE
7 +5
6 -15
5 -15
4 AE
3 AE
2 +15
1 +15

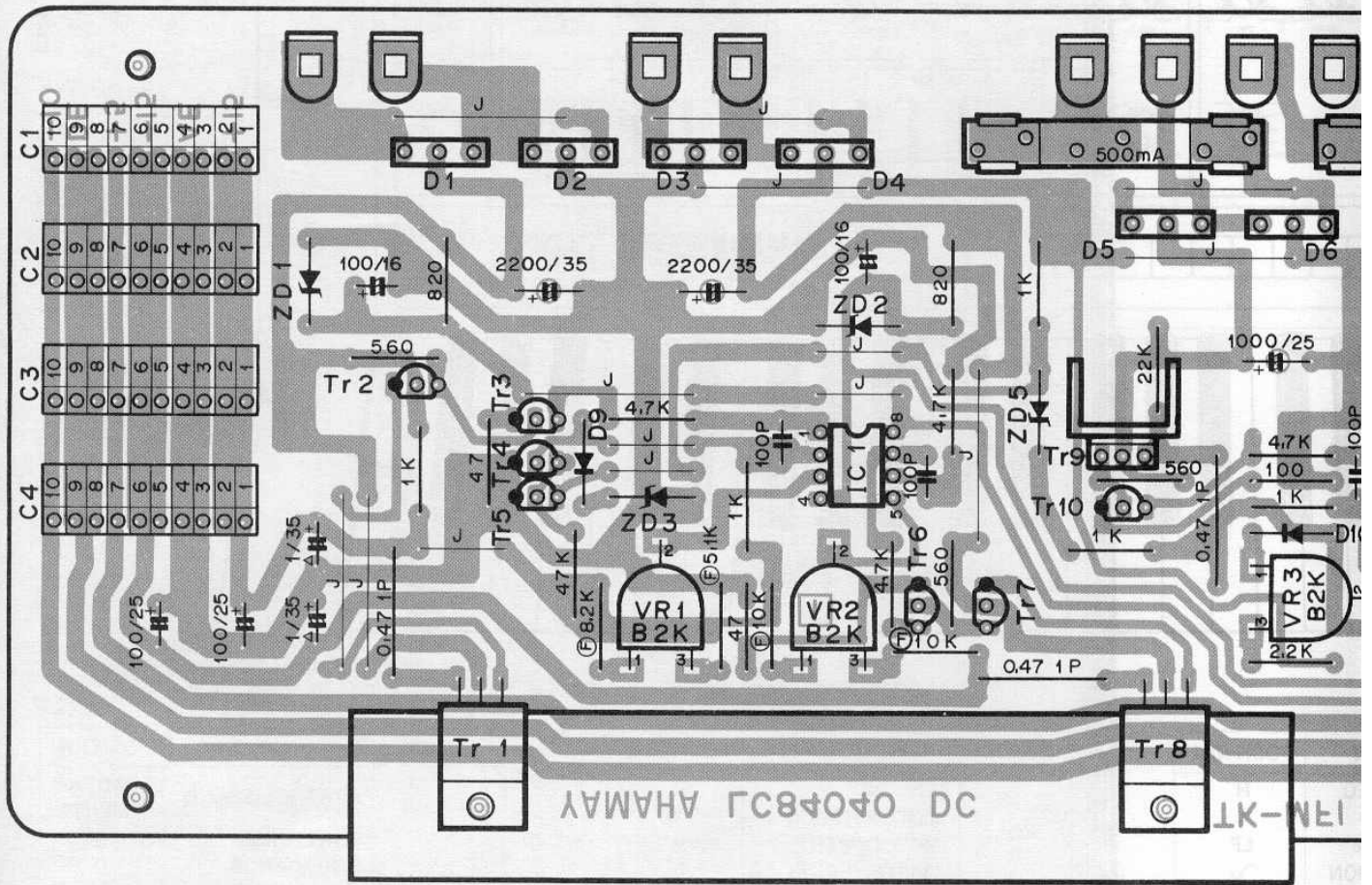

Note)

- |                            |                               |
|----------------------------|-------------------------------|
| 1. Circuit Board : LC84040 | 4. Diode                      |
| 2. IC                      | D1, 3, 5, 7 : 1D2C1           |
| IC1, 2 : NJM4558DV         | D2, 4, 6, 8 : 1D2Z1           |
| 3. Transistor              | D9, 10 : 1S1555               |
| Tr1, 9 : 2SD235            | ZD1, 2 : RD15EB3              |
| Tr2 : 2SC2120              | ZD4, 5 : RD3, 6EB1            |
| Tr3 ~5, 10 : 2SC1815       | 5. Capacitor                  |
| Tr6, 11 : 2SA1015          | △ marked : Tantalum Capacitor |
| Tr7 : 2SA950               |                               |
| Tr8, 12 : 2SA490           |                               |

# DC Circuit Board & Wiring

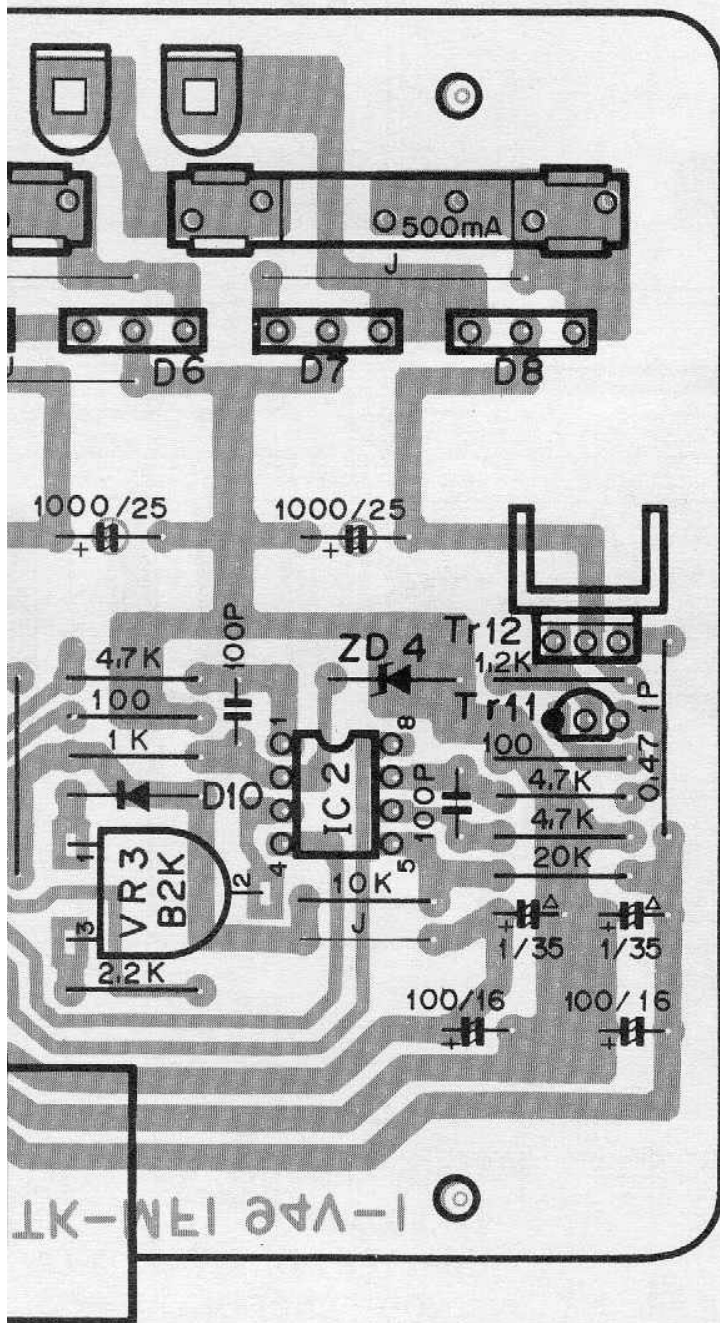

C1

Pin No.	Pin Name	Wire Color	Destination
1	+15	BR	PA+15 (C6-7)
2	+15	BR	PB+15 (C3-3)
3	AE	BL	PA-E (C6-6)
4	AE	BL	PB-E (C3-2)
5	-15	YE	PA-15 (C6-5)
6	-15	YE	PB-15 (C3-1)
7	+5	GR	PB+5 (C1-4)
8	DE	BL	PB-E (C1-3)
9	DE	BL	JK1-E (C2-8)
10	-10	BE	PB-10 (C1-1)

C2

Pin No.	Pin Name	Wire Color	Destination
1	+15	BR	PGM+15 (C5-4)
2	+15	BR	FA+15 (C1-9)
3	AE	BL	PGM-AE (C5-1)
4	AE	-	-
5	-15	YE	PGM-15 (C5-6)
6	-15	YE	FA-15 (C1-5)
7	+5	GR	PGM+5 (C4-1)
8	DE	BL	PGM-DE (C10-3)
9	DE	BL	JK1-DE (C1-3)
10	-10	BE	PGM-10 (C4-3)

C3

Pin No.	Pin Name	Wire Color	Destination
1	+15	BR	PA+15 (C4-1)
2	+15	BR	VCO+15 (C1-8)
3	AE	BL	PL-E (C2-3)
4	AE	BL	VCO-E (C1-6)
5	-15	YE	PA-15 (C4-4)
6	-15	YE	VCO-15 (C1-3)
7	+5	GR	MOD+5 (C1-7)
8	DE	BL	PGM-E (C4-10)
9	DE	BL	FA-E (C1-7)
10	-10	BE	MOD-10 (C1-5)

C4

Pin No.	Pin Name	Wire Color	Destination
1	+15	BR	SK+15 (C3-2)
2	+15	BR	PL+15 (C2-4)
3	AE	BL	SK-EK (C4-1)
4	AE	BL	JK1-EK (C2-4)
5	-15	YE	SK-15 (C3-3)
6	-15	YE	PL-15 (C2-2)
7	+5	GR	SK+5 (C3-7)
8	DE	BL	SK-DE (C3-4)
9	DE	-	-
10	-10	BE	SK-10 (C3-5)

# Electrical Checks & Adjustments

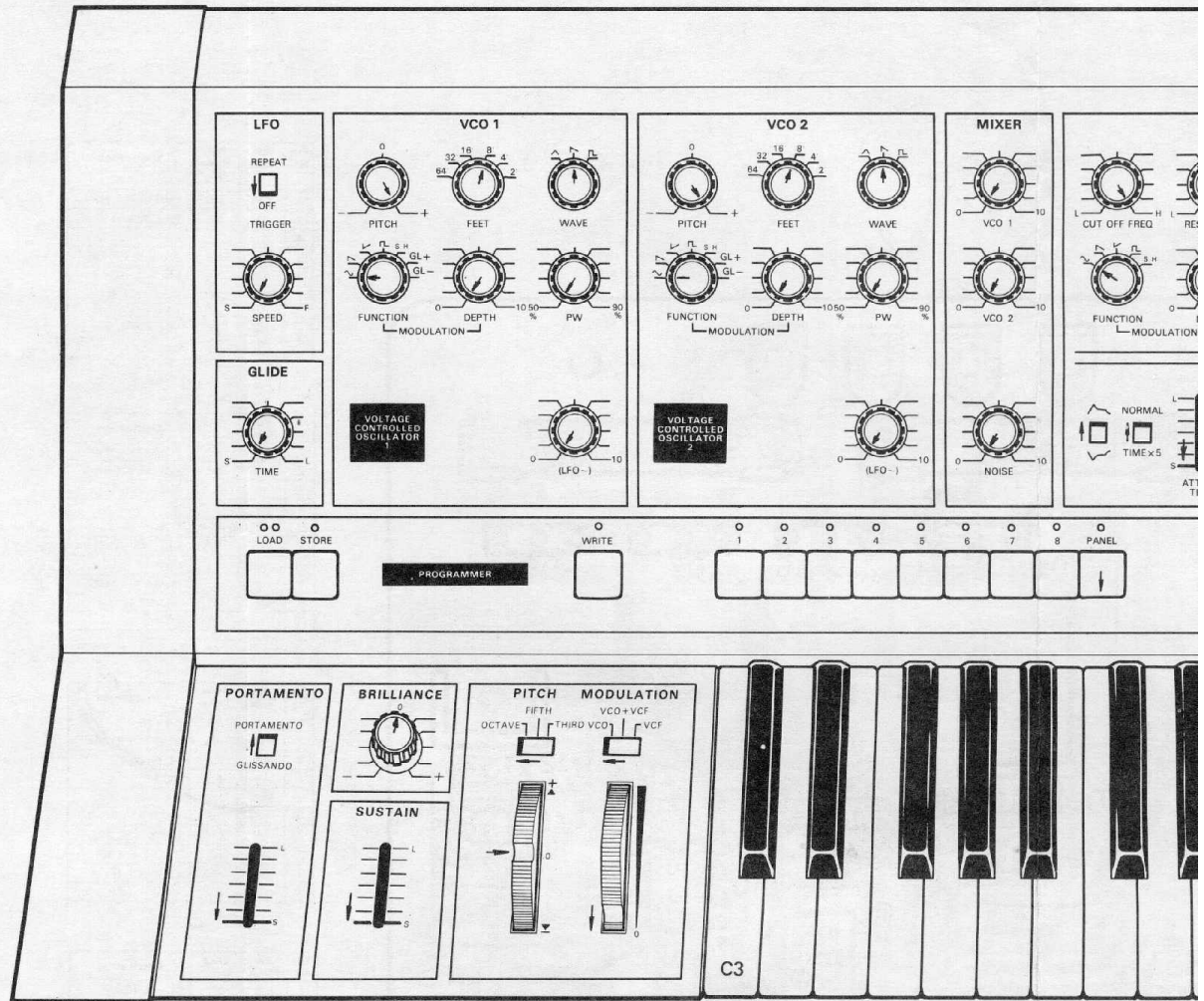

BLOCK	FUNCTION	POSITION
LFO	TRIGGER	OFF
	SPEED	S
GLIDE	TIME	S
VCO1, 2	PITCH	+
	FEET	8'
	WAVE	∩
	MOD. FUNCTION	~
	MOD. DEPTH	0
	PW	50%
	PWM (LFO~)	0
MIXER	VCO1	0
	VCO2	0
	NOISE	0

BLOCK	FUNCTION	POSITION
VCF	CUT OFF FREQ.	H
	RESONANCE	L
	FILTER MODE	LP
	MOD. FUNCTION	~
	MOD. DEPTH	0
	EG DEPTH	0
EG-VCF	POLARITY	∩
	TIME EXPAND	NORMAL
	ATTACK TIME	S
	DECAY TIME	S
	SUSTAIN LEVEL	10
	RELEASE TIME	S

BLOCK
VCA
EG-VCA
OUTPUT

# PANEL SETTING

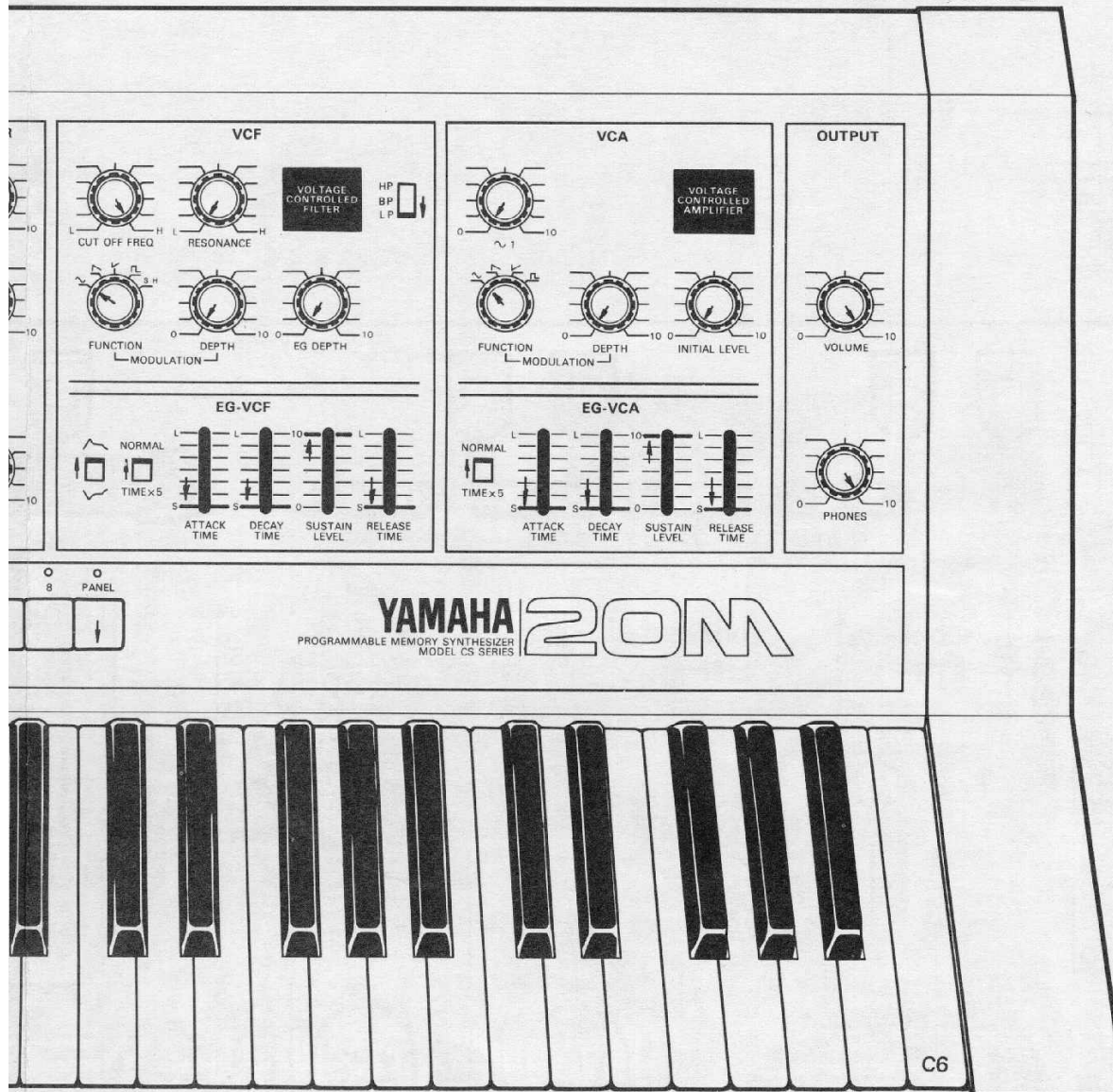

BLOCK	FUNCTION	POSITION
VCA	~1	0
	MOD. FUNCTION	~
	MOD. DEPTH	0
	INITIAL LEVEL	0
EG-VCA	TIME EXPAND	NORMAL
	ATTACK TIME	S
	DECAY TIME	S
	SUSTAIN LEVEL	10
	RELEASE TIME	S
OUTPUT	VOLUME	10
	PHONES	10

BLOCK	FUNCTION	POSITION
EFFECT	PORT./GLISSAND	PORTA-MENT
	PORT. TIME	S
	BRILLIANCE	0
	PITCH WHEEL	0
	LIMITER	OCTAVE
	MOD. WHEEL	0
PRO-GRAMMER	MOD. MODE	VCO
	SELECT BUTTON	PANEL

## TUNING (Do after supply voltage adjustment is completed.)

(The following procedure applies to VCO2 as well.)

1. Set the FEET in VCO1 (VCO2) to "4", then turn the VCO1 (VCO2) VR in the mixer fully clockwise.
2. Adjust the VCO1 HIGH VR on the rear panel until G7 + 12 cents is obtained when C6 key is depressed. Also adjust the VCO1 LOW VR until G4 + 12 cents is obtained when C3 key is depressed. (Observe the signal at the HIGH jack on the rear panel.)
3. Repeat above adjustments for keys C6 and C3 alternately until tuning accuracy of within  $\pm 2$  cents is obtained.

## SK Circuit Board

### 1. Supply Voltage Adjustment (This adjustment should be done after idling of more than 20 minutes.)

Test Point (SK Circuit Board)	Specification	Adjustment
+15 (CT1-2) -- EK (CT1-4)	+15 $\pm$ 0.01V	VR1 (DC Circuit Board)
-15 (CT1-3) -- EK (CT1-4)	-15 $\pm$ 0.01V	VR2 (DC Circuit Board)
+5 (CT2-3) -- DE (CT2-1)	+5 $\pm$ 0.05V	VR3 (DC Circuit Board)
-10 (CT2-2) -- DE (CT2-1)	-10 $\pm$ 0.5V	
VR (CT1-5) -- EK (CT1-4)	+2 $\pm$ 0.002V	VR3 (PL Circuit Board)
+4 (C3-4) -- E (PB. Circuit Board)	+4 $\pm$ 0.004V	VR2 (PB Circuit Board)

### 2. Clock Circuit for Portamento

Measuring Condition	Test Point	Specification	Adjustment (SK Circuit Board)
PORTAMENTO (PVR-45) → L	TP1	6 $\pm$ 0.6Hz	VR1
→ S	TP1	6 $\pm$ 0.6KHz	VR2

### 3. Comparator Circuit for Portamento

Measuring Condition		Test Point		
PORTAMENTO/GLISSAND (PSW-44)	PS (C4-6) terminal voltage	TP2	TP3	TP4
→ PORTAMENTO	STATE 1 +5V ~ +3.1V	0	1	1
"	STATE 2 +3.1V ~ +0.3V	1	1	1
"	STATE 3 +0.3V ~ -6.3V	1	0	1
"	STATE 4 -6.3V ~ -10V	1	0	0
→ GLISSANDO	"		1	

1 : +5V $\pm$ 0.5V  
0 : -10V $\pm$ 0.5V

#### 4. Key Asigner Circuit and Key Volt Circuit

4-1.

Condition	Test Point	Specification	Adjustment
C6 KEY ON	KV (CT1-1) -- EK (CT1-4)	+2 ± 0.002V	See the P51, PL Circuit Board adjustment

4-2. After the above adjustment is completed, depressing keys C3 to C6 should provide voltages each corresponding to those keys.

KEY	C3	F3	C4	F4	C5	F5	C6
Voltage	250.0	333.7	500.0	667.4	1000	1334	2000

[mV]

: Each voltage error should be ±0.3%.

4-3. When C6 key is depressed after C5 key is depressed, signal waveforms shown in Figure 1 should be obtained at terminal KV (C3-1).

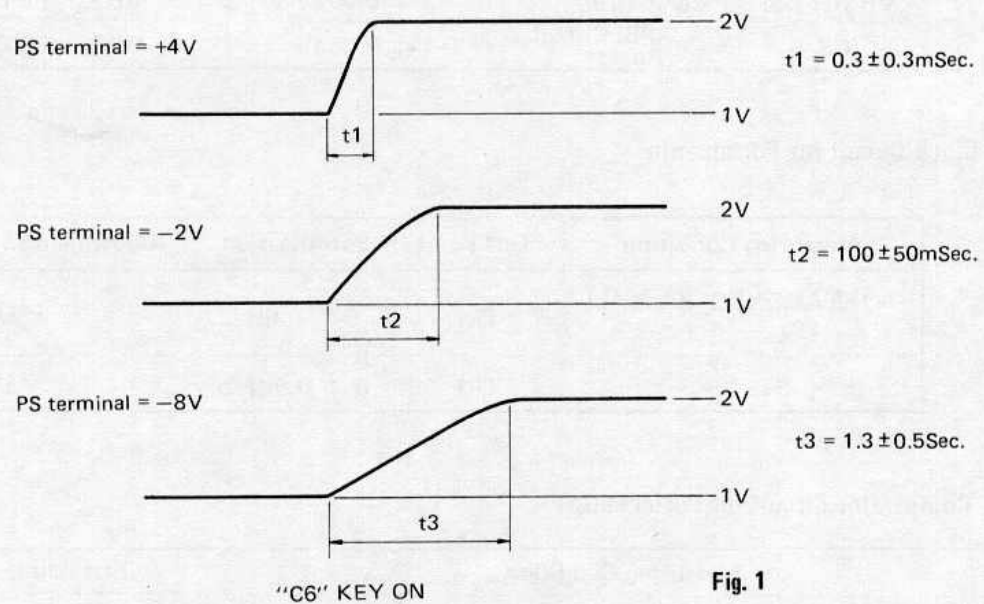

Fig. 1

Note: The specified voltage at terminal PS (C4-6) can be obtained with the PORTAMENTO slide adjustment (PVR-45).

4-4. When, in paragraph 4-3, the PORTAMENTO/GLISSANDO switch (PSW-44) is set to GLISSANDO, the signal waveform shown in Fig. 2 should be obtained.

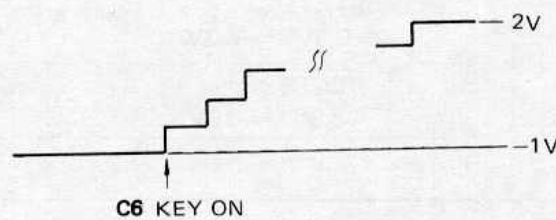

Fig. 2

### 5. Trigger Buffer

The signal waveform shown in Figure 3 should be obtained at terminal TR (C4-3) when keys C3 and C6 are depressed and released.

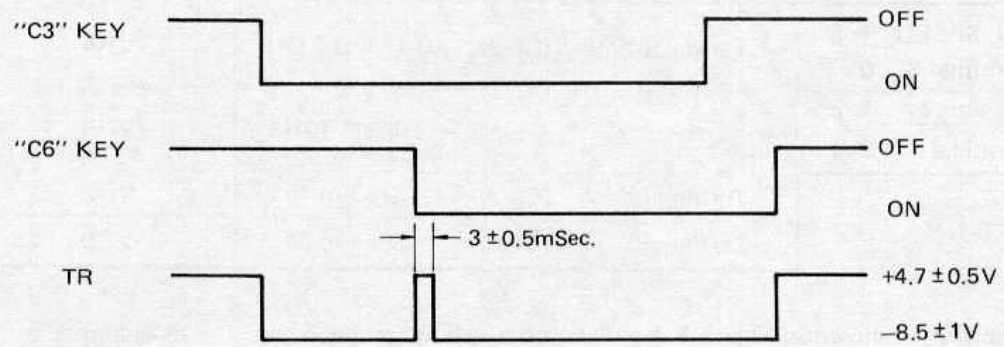

Fig. 3

# PA Circuit Board

## 1. LFO

1-1

Measuring Condition	Test Point	Specification	Adjustment	Remarks
LFO SPEED → S (Terminal S: 0V)	Terminal "∩" (C6-2)	$0.1 \pm 0.01\text{Hz}$	VR4	See Fig. 1.
LFO SPEED → F (Terminal S: 10V)	"	$100 \pm 10\text{Hz}$	VR3	See Fig. 1.
	Terminal "∩" (C6-3)	See Fig. 2	VR5	
	Terminal "⊥" (C1-6)	See Fig. 3	VR6	

1-2 Signal waveforms shown in Figure 1 should be obtained at terminals "∩" (C6-4) and "⊥" (C1-5).

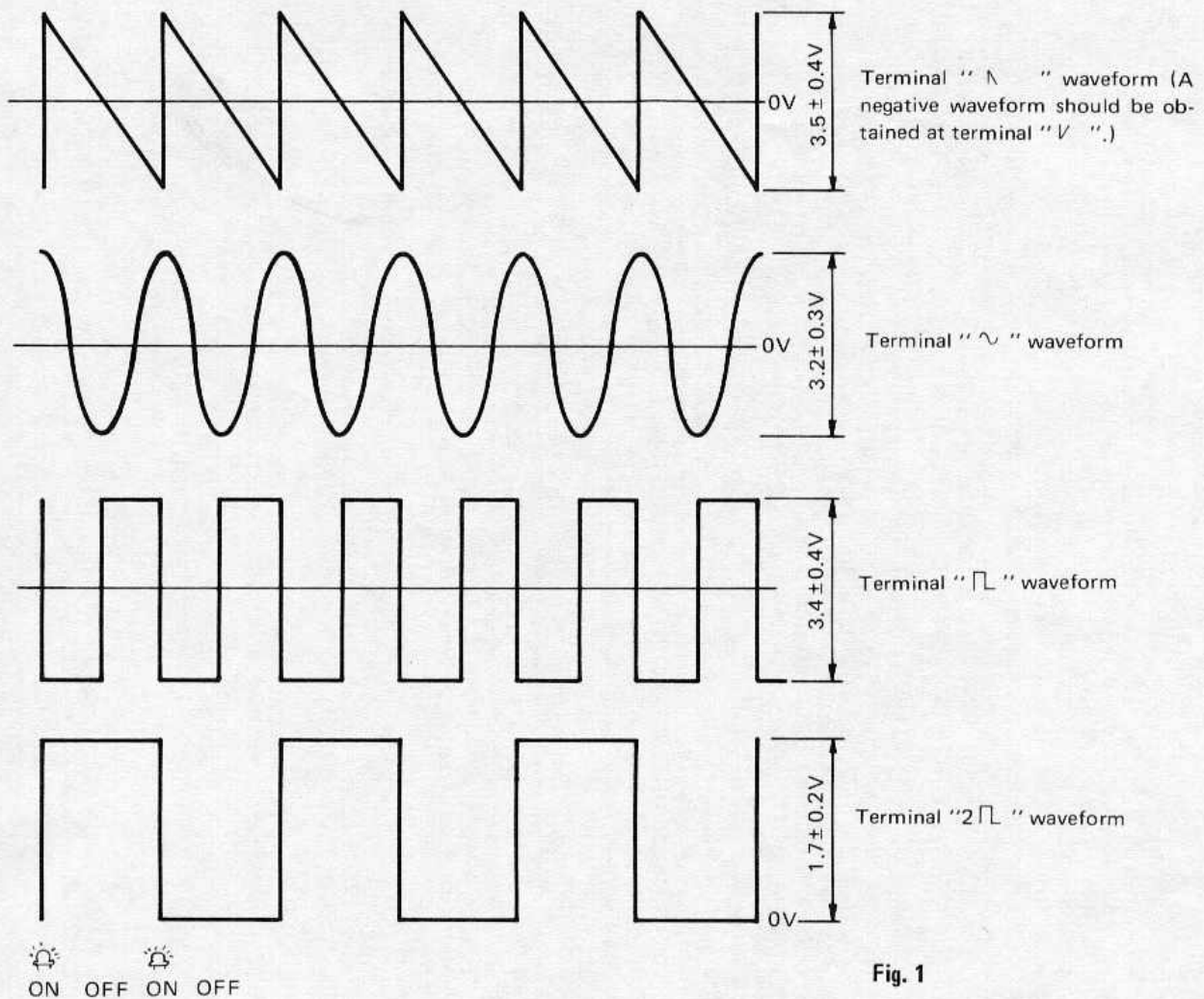
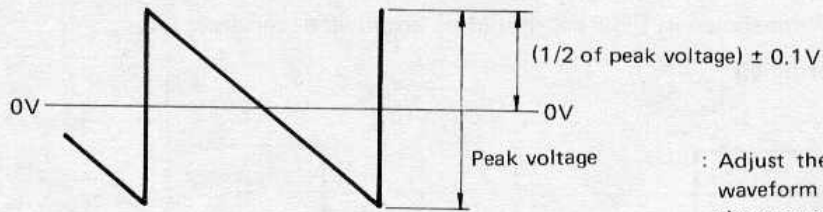
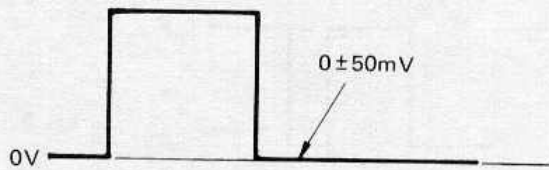

Fig. 1



**Fig. 2**

: Adjust the signal level until the waveform is symmetrical about the ground level.



**Fig. 3**

: Adjust bias voltage as shown in Figure 3.

1-3. When the signal shown in Figure 4 is applied to terminal TR (C7-5), the output at terminal "N" should be the one as shown in Figure 5. The signal shown in Figure 6 should be obtained at terminal LT (C7-2). (LFO SPEED → F)

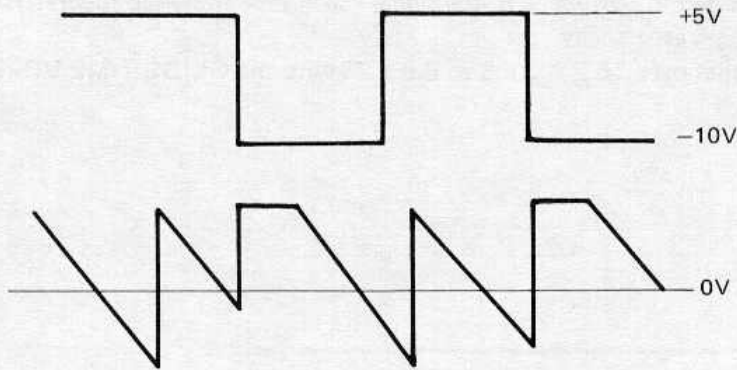

**Figure 4** Signal waveform applied to terminal TR (43Hz)

**Figure 5** Output signal at terminal "N"

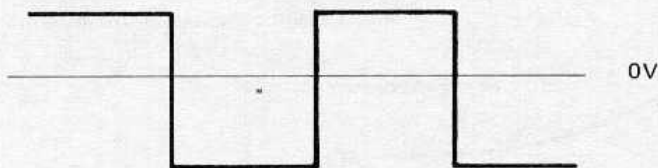

**Figure 6** Output signal at terminal LT

1-4. Set the LFO TRIGGER switch (PSW1) to REPEAT. When the signal shown in Figure 7 is applied to terminal TR, the signal waveform shown in Figure 8 should be obtained at terminal LT.  
 (Force +10V to S terminal)

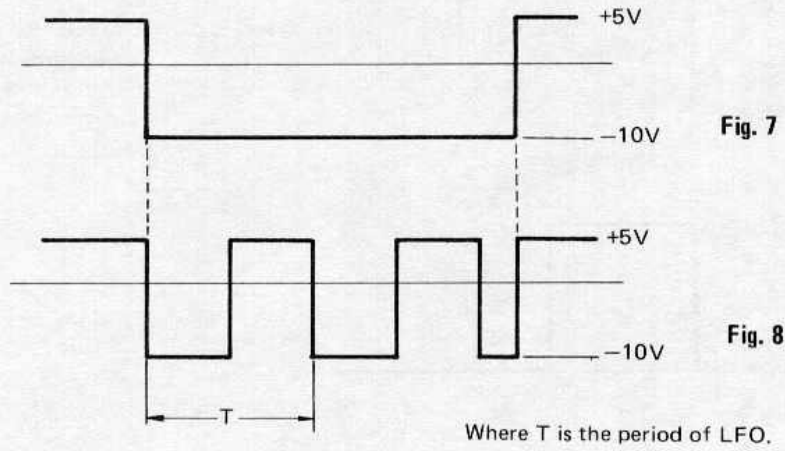

**2. Noise generator**

2-1. Adjust VR7 so that the output of WN terminal is  $+2 \pm 0.5\text{dBm}$ .

**3. Glide**

a. When the signal shown in Figure 9 is applied to terminal TR, the signal waveforms shown in Figures 10 and 11 should be obtained at terminals G+ and G—respectively.  
 Time T in the figures should be adjustable over  $16.2 \pm 3 \text{ mS}$  to  $6.9 \pm 2\text{S}$  with the GLIDE TIME VR (PVR 3).

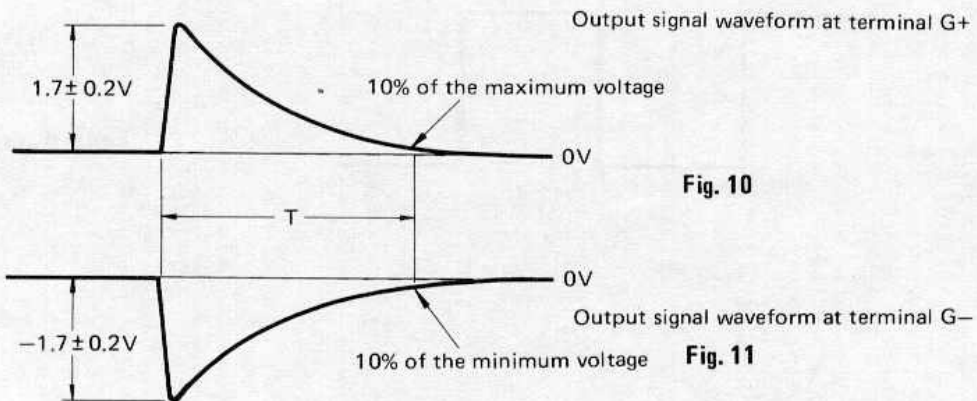
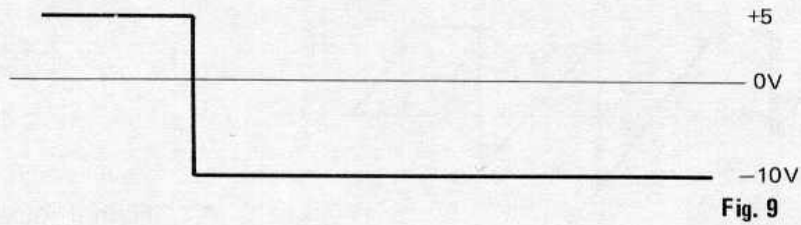

#### 4. Pitch

- 4-1. Connect terminal KV with terminal EK. Adjust VR1 and VR2 until the voltage across terminals CV1 and EK, and CV2 and EK is not more than  $\pm 0.1\text{mV}$ .
- 4-2. Depress C6 key to apply a +2V voltage across terminals KV and EK. When the PITCH control (PVR4) is turned fully clockwise, a voltage  $3 \pm 0.009\text{V}$  should be obtained at terminal CV1. When the PITCH control (PVR11) is turned fully clockwise, a voltage  $3 \pm 0.009\text{V}$  should be obtained at terminal CV2.
- 4-3. A voltage  $1.45 \pm 0.1\text{V}$  should be obtained at terminals CV1 and CV2 when the PITCH controls (PRV4 and PVR11) are turned fully counterclockwise.

## PB Circuit Board

### 1. EXP Circuit, Output Amplifier Circuit, and PHONE Amplifier Circuit:

1-1. (Terminal FC:  $-15V$ )

Turn VOLUME control (PVR42) fully clockwise. Apply a sine-wave signal with 1kHz,  $1 \pm 0.1V_{p-p}$  to terminal I and adjust VR1 until an output of 1kHz,  $2 \pm 0.2V$  is obtained at terminal HO (OUTPUT HIGH). At the time, an output of  $0.21 \pm 0.04V_{p-p}$  must be obtained at terminal LO (OUTPUT LOW).

1-2. When the voltage at terminal FC is held to the ground level, the output at terminal HO should vary over more than  $-36dB$ .

1-3. When a  $2V_{p-p}$  output is present at terminal HO, an output of  $0.8 \pm 0.2V_{p-p}$  should be obtained across terminals 0+ and 0- (with  $600 \Omega$  load provided across 0+ and 0-).

1-4. An output of  $0.38 \pm 0.1V_{p-p}$  should be obtained at terminals HL and HR when the PHONE level control (PVR43) is turned fully clockwise (with  $8 \Omega$  load provided across terminals HL and E, and HR and E).

### 2. Power Supply Circuit for EXP

$-14 \pm 1V$  voltage should be obtained at terminal  $-15'$ .

### 3. FEET Switching Circuit

FEET Switch	FT1 & FT2 terminal voltage	64' 64''	32' 32''	16' 16''	8' 8''	4' 4''	2' 2''
64'	(0 V)	1	0	0	0	0	0
32'	(0.67V)	0	1	0	0	0	0
16'	(1.33V)	0	0	1	0	0	0
8'	(2.00V)	0	0	0	1	0	0
4'	(2.67V)	0	0	0	0	1	0
2'	(3.33V)	0	0	0	0	0	1

1 :  $+5 \pm 0.5V$   
0 :  $-10 \pm 0.5V$

## VCO Circuit Board

### 1. VCO 1

1-1. Set the FEET switch to position 4'.

Adjust VR3 until the voltage across terminals TP1 and EK is  $0 \pm 0.1\text{mV}$ .

64' terminal	-10V
32' terminal	"
16' terminal	"
8' terminal	"
2' terminal	"
4' terminal	+5V

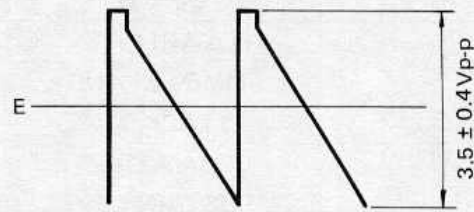

Fig. 1

1-2. While depressing C6 key, adjust VR2 until the signal waveform (4214.6Hz) shown in Figure 1 is obtained at terminal 01. (Voltage across terminals KV and EK:  $2 \pm 0.001\text{V}$ )

1-3. Set the FEET switch to position 32'. While depressing C6 key, adjust VR1 until a 526.8Hz output is obtained at terminal 01. (Voltage across terminals KV and EK:  $250 \pm 0.1\text{mV}$ )

1-4. Repeat steps 1-2 and 1-3 alternately until each frequency error is within  $\pm 0.1\%$ .

1-5. When a voltage +2V is applied to terminal V1, the output frequency should be 800 ~ 900Hz.

1-6. When C6 key is depressed, frequencies shown in Table 1 should be obtained at terminal 01.

FEET Switch	Terminal 01
2'	8429
4'	4214.6
8'	2107
16'	1053.6
32'	526.8
64'	263.4

1-7. Do the same adjustments for VCO2.

## FA Circuit Board

### 1. EG-VCF

#### Measuring Condition

BLOCK	FUNCTION	POSITION	Terminal Voltage
VCF	EG DEPTH	10	Terminal EL +10V
EG-VCF	POLARITY		POL +10V
	TIME EXPAND	NORMAL	T5F 0V
	ATTACK TIME	Note 1	AF 8V
	DECAY TIME	S	DF +10V
	SUSTAIN LEVEL	0	SF 0V
EFFECT	RELEASE TIME	S	FRI +10V
	SUSTAIN	S	RF +10V

Table 1.

Note 1: Adjust ATTACK TIME so the voltage at terminal AF is 8 volts.

1-1. When a key is depressed under the condition shown in Table 1, the signal waveform shown in Fig. 1 should be obtained at TP1.

VR6	Adjusts signal level
VR7	Adjust this until T is 4mS

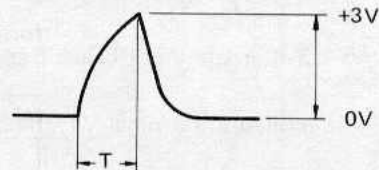

Fig. 1

1-2. Apply +3VDC to terminal AF. Adjust VR9 so period T is much larger than 125mS when it is larger than 125mS, and is much smaller than 125mS when it is smaller than 125mS.

1-3. Repeat steps 1-1 and 1-2 alternately.

1-4. Use VR8 to adjust the ground level of the output signal at terminal TP1.

1-5. When the TIME X5 switch is activated (terminal T5F : 4V) the period of the output signal at TP1 should be multiplied by  $5.5 \pm 1.5$ .

1-6. When the voltage at terminal POL is ground level, the output signal at TP1 should be the inversion of the one shown in Fig. 1, with the level difference within +10%.

### 2. EG-VCA

#### Measuring Condition

BLOCK	FUNCTION	POSITION	Terminal Voltage
VCO	INITIAL LEVEL	0	IL 0V
EG-VCF	TIME EXPAND	NORMAL	T5A 0V
	ATTACK TIME	(Note 2)	AA 8V
	DECAY TIME	S	DA +10V
	SUSTAIN LEVEL	0	SA 0V
	RELEASE TIME	S	ARI +10V
EFFECT	SUSTAIN	S	RA +10V

Note 2: Adjust ATTACK time so the voltage at terminal AA is 8 volts.

2-1. When a Key is depressed, the signal waveform shown in Fig. 2 should be obtained at TP2.

VR16	Adjust signal level
VR11	Adjust this until T is 4mS

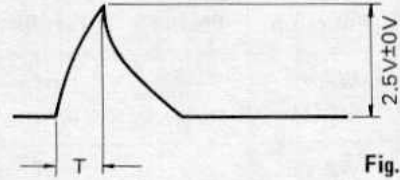

Fig. 2

2-2. Adjust ATTACK TIME, then apply +3VDC to terminal AA.

Adjust VR14 so period T is much larger than 125mS when it is larger than 125mS, and is much smaller than 125mS when it is smaller than 125mS.

2-3. Repeat steps 2-1 and 2-2 alternately.

2-4. Use VR12 to adjust the ground level of the output signal at terminal TP2.

2-5. When the TIME X5 switch (terminal T5A: 4V) is activated, the period T of the output signal at TP2 should be multiplied by  $5.5 \pm 1.5$ .

### 3. Wave Shape Converter

WSC1

Block	Function	Position	Terminal Voltage	TP3 Output Signal
VCO	WAVE		Terminal HB1 0V	Fig. 3 
	WAVE		Terminal HB1 1.33V	Fig. 4 
	WAVE		Terminal HB1 2.67V	Fig. 5 
	WAVE PW	 90	Terminal P1 1.5V	Fig. 6 

Note: WSC1 FEET 8' key C5.  
WSC2 FEET 8' key C4.

#### 4. Mixing Circuit

Block	Function	Position	Terminal Voltage		Adjustment
VCO1 MIXER	WAVE VCO1	∧ 10	HB1 C1	0V +10V	Adjust VR1 until a triangular signal of $3.4 \pm 0.4V$ is obtained at TP5. (See Fig. 3.)
VCO2 MIXER	WAVE VCO2	∧ 10	HB2 C2	0V +10V	Adjust VR2 until a triangular signal of $3.4 \pm 0.4V$ is obtained at TP5.
MIXER	NOISE	10	C3	+10V	* Apply a sine-wave signal of 1kHz, 3Vp-p to terminal NI. Adjust VR3 until a sine-wave signal of 3Vp-p is obtained.
VCA	~ 1	10	C4	+10V	Adjust VR10 until a sine-wave signal of 3Vp-p is obtained at TP6.

#### 4. VCF

##### Measuring Condition

Block	Function	Position	Terminal Voltage	
EFFECT	BRILLIANCE	0	BR	0V
VCF	MODULATION DEPTH	0	CM	0V
	EG-DEPTH	0	EL	0V
	FILTER MODE	LP	FC	0V
	CUT OFF FREQ.	Adjust the CUT OFF FREQ. until the voltage at terminal CO is 5V.	CO	5V
	RESONANCE	Adjust the RESONANCE until the voltage at terminal RE is 5V.	RE	5V
MIXER	VCO1	0	C1	0V
	VCO2	0	C2	0V
	NOISE	10	C3	+10V
VCA	~ 1	0	C4	0V

- Apply a sine-wave signal of 1kHz, 3Vp-p to terminal NI
- Depress C4 key. (Terminal KV: 500mV)

5-1. Use VR4 to adjust peak point and VR5 to adjust peak level until an output of 1kHz, 1.75Vp-p is obtained at TP7.

5-2. Set the voltage at terminal CO to 7V. The peak frequency at TP7 should be  $4 \pm 1kHz$ . (Check peak point while the input frequency at terminal NI is varied.)

5-3. Set the RESONANCE level to "H" (terminal RE: 10V). An output of  $0.6 \pm 0.15Vp-p$  should be obtained at TP7.

5-4. Set the RESONANCE level to "L" (terminal RE: 0V). An output of  $6 \pm 1Vp-p$  should be obtained at TP7.

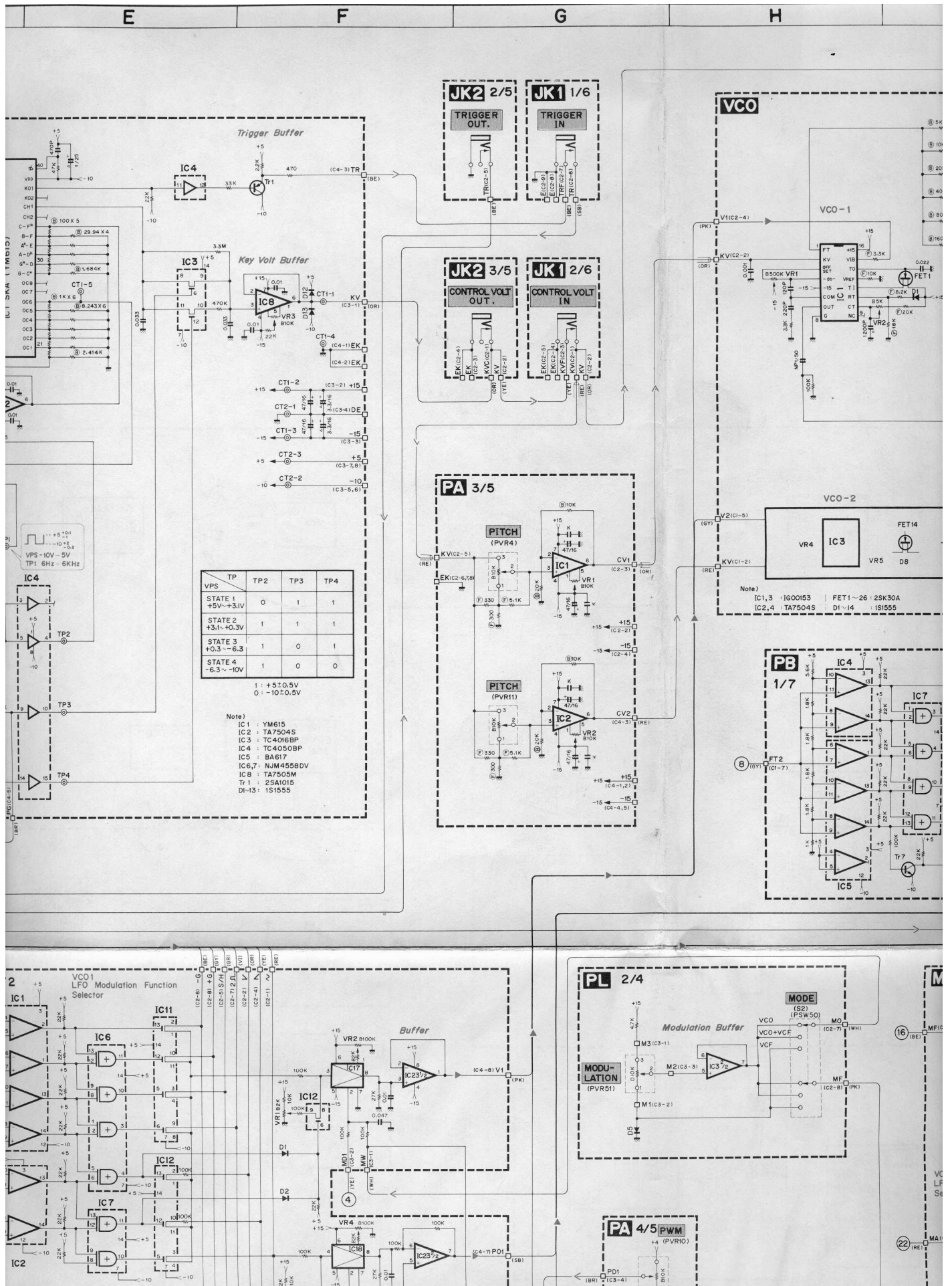

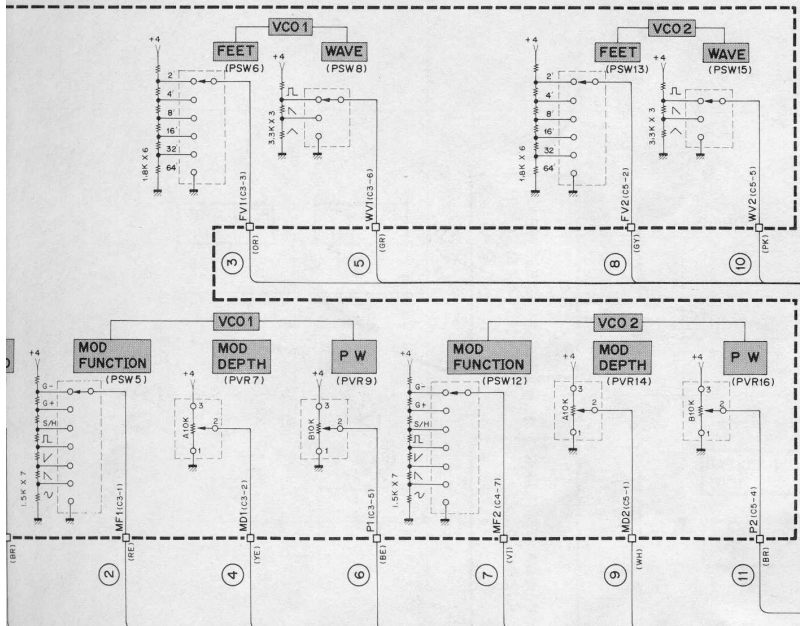
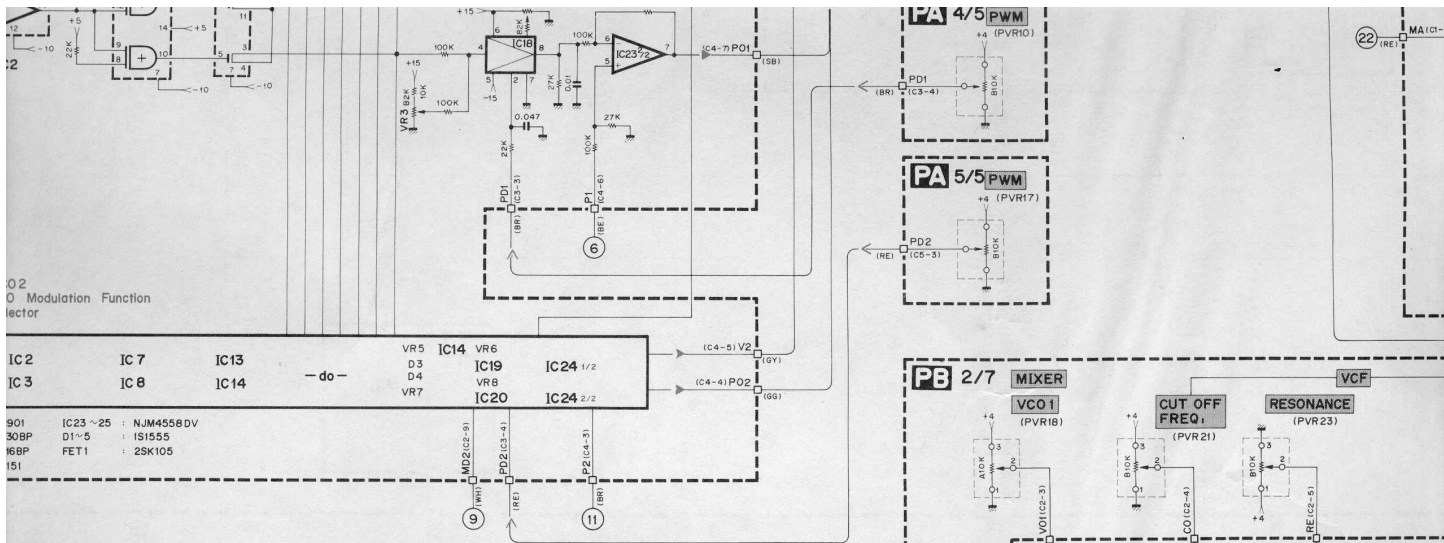

PB

VCO

FA

C1 C5 C1 C1 C4

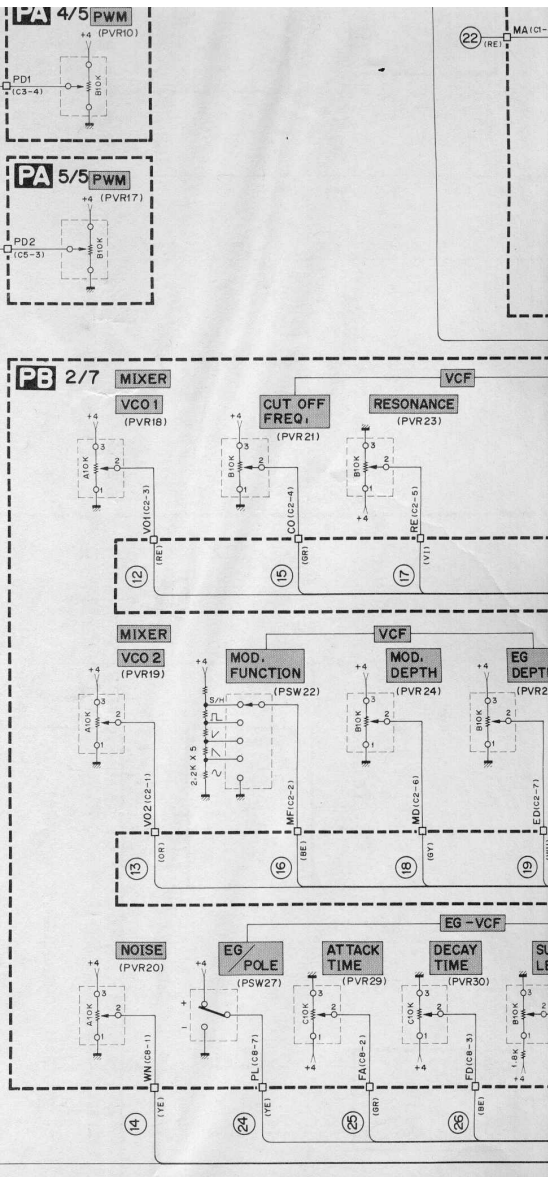

C1 C4

# PB

## C1

Wire Color	Destination
BE	DC-10 (C1-10)
BE	PA-10 (C7-4)
BL	DC-DE (C1-8)
GR	DC-15 (C1-7)
GR	PA-15 (C7-1)
OR	DM-3 (C5-7)
GY	DM-8 (C5-2)

## C2

Wire Color	Destination
OR	PGM-13 (C7-8)
BE	PGM-16 (C7-5)
RE	PGM-12 (C7-9)
GR	PGM-15 (C7-6)
VI	PGM-17 (C7-4)
GY	PGM-18 (C7-3)
WH	PGM-19 (C7-2)
YE	JK1-15 (C1-7)

## C3

Wire Color	Destination
YE	DC-15 (C1-6)
BL	DC-AE (C1-4)
BR	DC+15 (C1-2)
VI	PA+4 (C4-6)
PK	PGM-20 (C7-1)
RE	PGM-22 (C9-3)
BR	PGM-21 (C9-4)
OR	PGM-23 (C9-2)
GG	FA-IL (C3-2)
RE	FA-O1 (C5-1)
OR	JK1-PC (C1-8)

## C4

Wire Color	Destination
RE	HP-HR
OR	HP-HL
BE	JK1-HO (C1-1)
BES	
VIS	
IVI	SK2-LO (C1-1)
BL	JK1-E (C1-4)
BL	FA-E (C5-3)
RE	XLR-3
WH	XLR-2

## C5

Pin No.	Pin Name	Wire Color	Destination
1	AA	WH	PGM-29 (C8-5)
2	AD	PK	PGM-30 (C8-6)
3	AS	BR	PGM-31 (C9-6)
4	AR	RE	PGM-32 (C9-5)
5	X5	BR	FA-T5A (C3-4)

## C6

Pin No.	Pin Name	Wire Color	Destination
1	2"	BR	VCO-2" (C4-6)
2	4"	RE	VCO-4" (C4-5)
3	8"	OR	VCO-8" (C4-4)
4	16"	YE	VCO-16" (C4-3)
5	32"	GR	VCO-32" (C4-2)
6	64"	BE	VCO-64" (C4-1)

## C7

Pin No.	Pin Name	Wire Color	Destination
1	2'	BR	VCO-2' (C3-6)
2	4'	RE	VCO-4' (C3-5)
3	8'	OR	VCO-8' (C3-4)
4	16'	YE	VCO-16' (C3-3)
5	32'	GR	VCO-32' (C3-2)
6	64'	BE	VCO-64' (C3-1)

## C8

Pin No.	Pin Name	Wire Color	Destination
1	WN	YE	PGM-14 (C7-7)
2	FA	GR	PGM-25 (C8-7)
3	FD	BE	PGM-26 (C8-2)
4	FS	VI	PGM-27 (C8-3)
5	FR	GY	PGM-28 (C8-4)
6	X5	RE	FA-T5F (C3-5)
7	PL	YE	PGM-24 (C9-1)

# VCO

## C1

Pin No.	Pin Name	Wire Color	Destination
1	EK	BL	PA-EK (C2-8)
2	KV	RE	PA-CV2 (C4-3)
3	-15	YE	DC-15 (C3-6)
4	-15	YE	VCO-15 (C2-3)
5	V2	GY	MOD-V2 (C4-5)
6	E	BL	DC-AE (C3-4)
7	E	BL	VCO-E (C2-5)
8	+15	BR	DC+15 (C3-2)
9	+15	BR	VCO+15 (C2-8)
10	O2	RE	FA-SI2 (C1-3)

## C2

Pin No.	Pin Name	Wire Color	Destination
1	EK	SORS	
2	KV	SOR	PA-CV1 (C2-3)
3	-15	YE	VCO-15 (C1-4)
4	V1	PK	MOD-V1 (C4-8)
5	E	BL	VCO-E (C1-7)
6	+15	BR	VCO+15 (C1-9)
7	O1	BR	FA-SI1 (C1-1)

## C3

Pin No.	Pin Name	Wire Color	Destination
1	64'	BE	PB-64' (C7-6)
2	32'	GR	PB-32' (C7-5)
3	16'	YE	PB-16' (C7-4)
4	8'	OR	PB-8' (C7-3)
5	4'	RE	PB-4' (C7-2)
6	2'	BR	PB-2' (C7-1)

## C4

Pin No.	Pin Name	Wire Color	Destination
1	64"	BE	PB-64" (C6-6)
2	32"	GR	PB-32" (C6-5)
3	16"	YE	PB-16" (C6-4)
4	8"	OR	PB-8" (C6-3)
5	4"	RE	PB-4" (C6-2)
6	2"	BR	PB-2" (C6-1)

# FA

## C1

Pin No.	Pin Name	Wire Color	Destination
1	SI1	BR	VCO-O1 (C2-7)
2	P1	SB	MOD-PO1 (C4-7)
3	SI2	RE	VCO-O2 (C1-10)
4	P2	GG	MOD-PO2 (C4-4)
5	-15	YE	DC-15 (C2-6)
6	-15	YE	MOD-15 (C3-9)
7	E	BL	DC-DE (C3-9)
8	E	BL	MOD-E (C3-8)
9	+15	BR	DC+15 (C2-2)
10	+15	BR	MOD+15 (C3-10)

## C2

Pin No.	Pin Name	Wire Color	Destination
1	+5	GR	MOD+5 (C1-8)
2	+5	GR	FA+5 (C4-9)
3	-10	BE	MOD-10 (C1-6)
4	-10	BE	FA-10 (C4-10)
5	E	-	-
6	HB2	PK	DM-10 (C4-9)
7	HB1	GR	DM-5 (C5-5)
8	POL	YE	DM-24 (C3-5)
9	FC	PK	DM-20 (C3-9)

## C3

Pin No.	Pin Name	Wire Color	Destination
1	EL	WH	DM-19 (C3-10)
2	IL	GG	PB-IL (C3-9)
3	A	SB	MOD-A (C4-1)
4	T5A	BR	PB-X5 (C5-5)
5	T5F	RE	PB-X5 (C8-6)
6	T1	GR	PA-LT (C7-3)

## C4

Pin No.	Pin Name	Wire Color	Destination
1	AF	GR	DM-25 (C3-4)
2	DF	BE	DM-26 (C3-3)
3	RF	YE	PL-FRO (C1-8)
4	SF	VI	DM-27 (C3-2)
5	AA	WH	DM-29 (C2-7)
6	DA	PK	DM-30 (C2-6)
7	RA	OR	PL-ARO (C1-9)
8	SA	BR	DM-31 (C2-5)
9	+5	GR	FA+5 (C2-2)
10	-10	BE	FA-10 (C2-4)

## C5

Pin No.	Pin Name	Wire Color	Destination
1	O1	SRE	PB-1 (C3-10)
2	E	SRES	
3	E	BL	PB-E (C4-8)
4	C4	BR	DM-21 (C3-8)
5	KV	OR	JK1-KV (C2-2)
6	CO	GR	DM-15 (C4-4)
7	CM	YE	MOD-F (C4-2)
8	BR	BE	PL-BR (C2-5)
9	RE	VI	DM-17 (C4-2)

## C6

Pin No.	Pin Name	Wire Color	Destination
1	NI	SWH	PA-WN (C1-3)
2	E	SWHS	
3	C3	YE	DM-14 (C4-5)
4	C1	RE	DM-12 (C4-7)
5	C2	OR	DM-13 (C4-6)

# CS-20M OVERALL CIRCUIT DIAGRAM

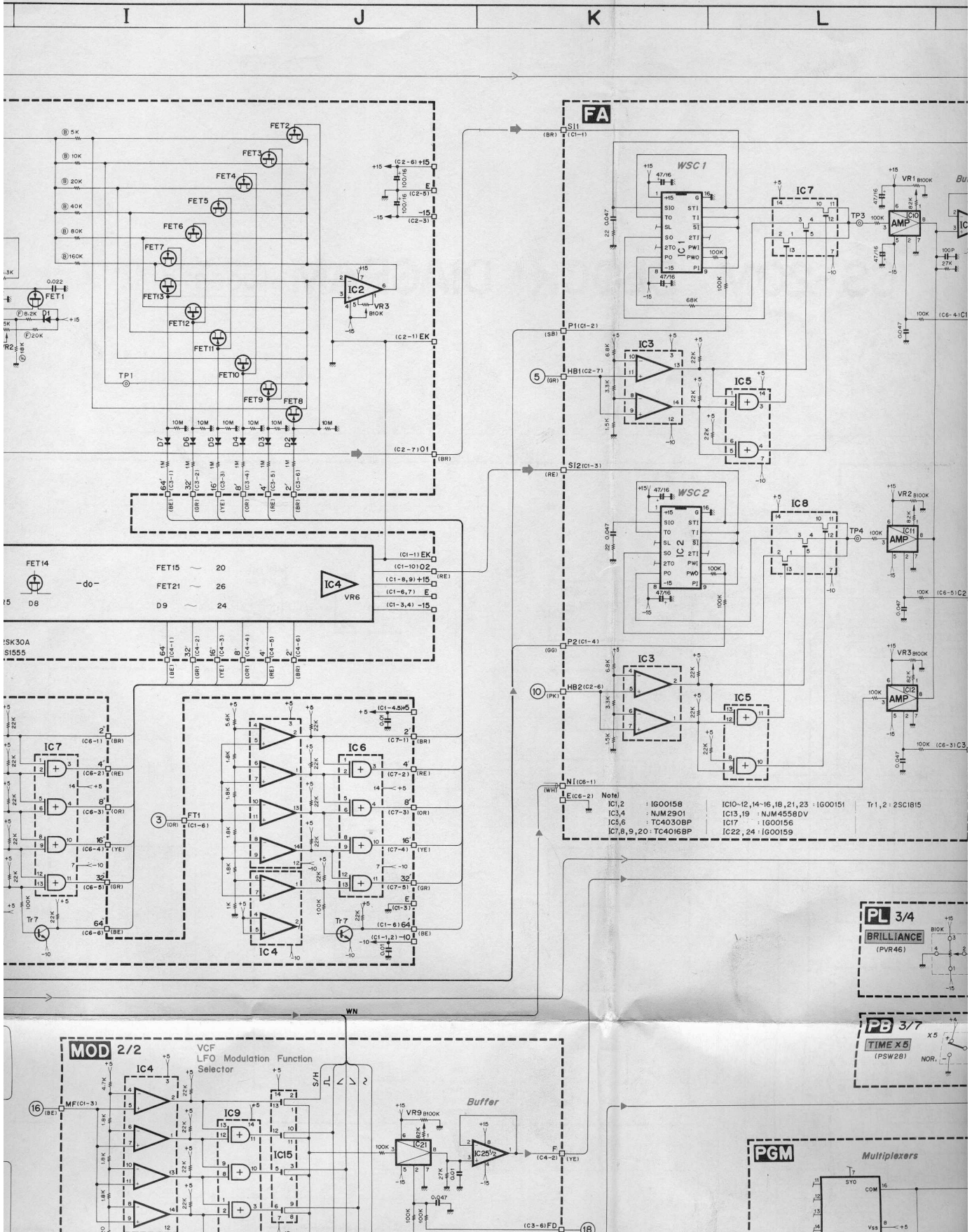

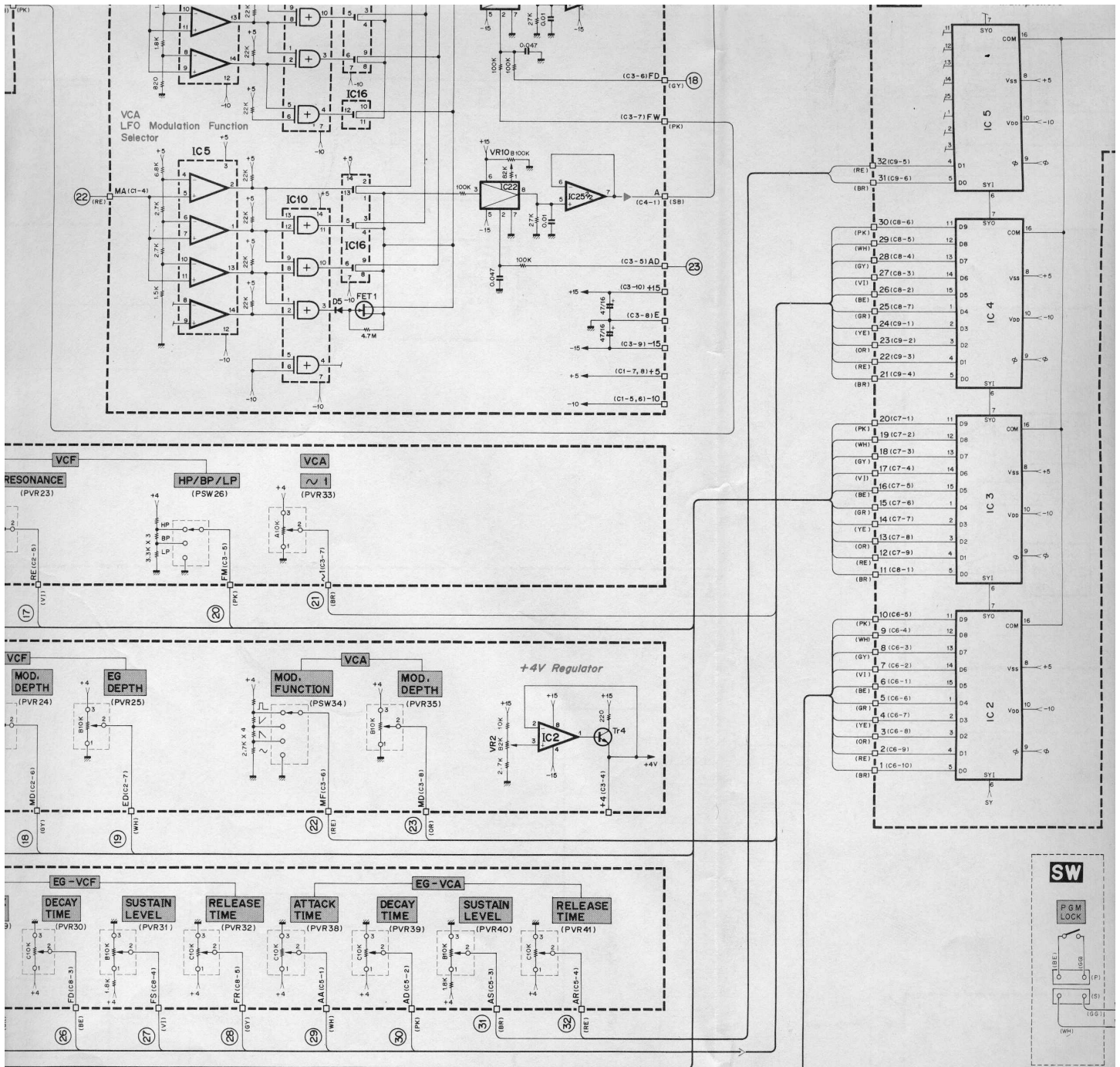

MOD

PGM

## MOD

## PGM

C4

Wire Color	Destination
GR	DM-25 (C3-4)
BE	DM-26 (C3-3)
YE	PL-FRO (C1-8)
VI	DM-27 (C3-2)
WH	DM-29 (C2-7)
PK	DM-30 (C2-6)
OR	PL-ARO (C1-9)
BR	DM-31 (C2-5)
GR	FA+5 (C2-2)
BE	FA-10 (C2-4)

C5

Wire Color	Destination
SRE	PB-I (C3-10)
SRES	
BL	PB-E (C4-8)
BR	DM-21 (C3-8)
OR	JK1-KV (C2-2)
GR	DM-15 (C4-4)
YE	MOD-F (C4-2)
BE	PL-BR (C2-5)
VI	DM-17 (C4-2)

C6

Wire Color	Destination
SWH	FA-WN (C1-3)
SWHS	
YE	DM-14 (C4-5)
RE	DM-12 (C4-7)
OR	DM-13 (C4-6)

C1

Pin No.	Pin Name	Wire Color	Destination
1	MF1	RE	DM-2 (C5-8)
2	MF2	VI	DM-7 (C5-3)
3	MF	BE	DM-16 (C4-3)
4	MA	RE	DM-22 (C3-7)
5	-10	BE	DC-10 (C3-10)
6	-10	BE	FA-10 (C2-3)
7	+5	GR	DC+5 (C3-7)
8	+5	GR	FA+5 (C2-1)

C2

Pin No.	Pin Name	Wire Color	Destination
1	~	RE	PA-~ (C6-2)
2	V	OR	PA-V (C6-4)
3	Π	WH	PA-Π (C1-5)
4	∩	YE	PA-∩ (C6-3)
5	S/H	GR	PA-S/H (C1-4)
6	G <sup>-</sup>	BE	PA-G <sup>-</sup> (C1-2)
7	2 Π	VI	PA-2 Π (C1-6)
8	G <sup>+</sup>	GY	PA-G <sup>+</sup> (C1-1)
9	MD2	WH	DM-9 (C5-1)

C3

Pin No.	Pin Name	Wire Color	Destination
1	MW	WH	PL-MO (C2-7)
2	MD1	YE	DM-4 (C5-6)
3	PD1	BR	PA-PD1 (C3-4)
4	PD2	RE	PA-PD2 (C5-3)
5	AD	OR	DM-23 (C3-6)
6	FD	GY	DM-18 (C4-1)
7	FW	PK	PL-MF (C2-8)
8	E	BL	FA-E (C1-8)
9	-15	YE	FA-15 (C1-6)
10	+15	BR	FA+15 (C1-10)

C4

Pin No.	Pin Name	Wire Color	Destination
1	A	SB	FA-A (C3-3)
2	F	YE	FA-CM (C5-7)
3	P2	BR	DM-11 (C4-8)
4	PO2	GG	FA-P2 (C1-4)
5	V2	GY	VCO-V2 (C1-5)
6	P1	BE	DM-6 (C5-4)
7	PO1	SB	FA-P1 (C1-2)
8	V1	PK	VCO-V1 (C2-4)

C1

Pin No.	Pin Name	Wire Color	Destination
1	1B	BR	BL-1B (C2-1)
2	2B	RE	BL-2B (C2-2)
3	3B	OR	BL-3B (C2-3)
4	4B	YE	BL-4B (C2-4)
5	5B	GG	BL-5B (C2-5)
6	6B	SB	BL-6B (C3-5)
7	7B	VI	BL-7B (C3-6)
8	8B	GY	BL-8B (C3-7)

C2

Pin No.	Pin Name	Wire Color	Destination
1	8L	GY	BL-8L (C3-2)
2	2L	RE	BL-2L (C2-9)
3	4L	YE	BL-4L (C2-7)
4	3L	OR	BL-3L (C2-8)
5	1L	BR	BL-1L (C2-10)
6	5L	GR	BL-5L (C2-6)
7	7L	VI	BL-7L (C3-3)

C3

Pin No.	Pin Name	Wire Color	Destination
1	WL	WH	BL-WL (C2-11)
2	PL	GG	BL-PL (C3-1)
3	GL	BE	BL-GL (C3-4)
4	LL	PK	BL-LL1 (C1-2)
5	SL	SB	BL-SL (C1-1)

C4

Pin No.	Pin Name	Wire Color	Destination
1	+5	GR	DC+5 (C2-7)
2	+5	GR	DM+5 (C1-2)
3	-10	BE	DC-10 (C2-10)
4	-10	BE	DM-10 (C1-5)
5	LI	OR	BL-LL2 (C1-3)
6	E	SWHS	
7	CO	SWH	JK1-PGT (C2-10)
8	E	SVIS	
9	CI	SVI	JK2-PGF (C2-6)
10	E	BL	DC-DE (C3-8)

C5

Pin No.	Pin Name	Wire Color	Destination
1	AE	BL	DC-AE (C2-3)
2	AE	BL	DM-E (C2-3)
3	AO	BR	DM-AI (C2-1)
4	+15	BR	DC+15 (C2-1)
5	+15	BR	DM+15 (C2-2)
6	-15	YE	DC-15 (C2-5)
7	-15	YE	DM-15 (C2-4)

C6

Pin No.	Pin Name	Wire Color	Destination
1	6	BE	PA-P1 (C3-5)
2	7	VI	PA-MF2 (C4-7)
3	8	GY	PA-FV2 (C5-2)
4	9	WH	PA-MD2 (C5-1)
5	10	PK	PA-WV2 (C5-5)
6	5	GR	PA-WV1 (C3-6)
7	4	YE	PA-MD1 (C3-2)
8	3	OR	PA-FV1 (C3-3)
9	2	RE	PA-MF1 (C3-1)
10	1	BR	PA-LS (C2-1)

C7

Pin No.	Pin Name	Wire Color	Destination
1	20	PK	PB-FM (C3-5)
2	19	WH	PB-ED (C2-7)
3	18	GY	PB-MD (C2-6)
4	17	VI	PB-RE (C2-5)
5	16	BE	PB-MF (C2-2)
6	15	GR	PB-CO (C2-4)
7	14	YE	PB-WN (C8-1)
8	13	OR	PB-VO2 (C2-1)
9	12	RE	PB-VO1 (C2-3)

C8

Pin No.	Pin Name	Wire Color	Destination
1	11	BR	PA-P2 (C5-4)
2	26	BE	PB-FD (C8-3)
3	27	VI	PB-FS (C8-4)
4	28	GY	PB-FR (C8-5)
5	29	WH	PB-AA (C5-1)
6	30	PK	PB-AD (C5-2)
7	25	GR	PB-FA (C8-2)

C9

Pin No.	Pin Name	Wire Color	Destination
1	24	YE	PB-PL (C8-7)
2	23	OR	PB-MD (C3-8)
3	22	RE	PB-MF (C3-6)
4	21	BR	PB-~1 (C3-7)
5	32	RE	PB-AH (C5-4)
6	31	BR	PB-AS (C5-3)

C10

Pin No.	Pin Name	Wire Color	Destination
1	∅	PK	DM-∅ (C1-4)
2	VB	OR	VE-BB
3	DE	BL	DC-DE (C2-8)
4	DE	BL	E-BB
5	P	PK	BL-PB (C3-8)
6	W	WH	BL-WB (C1-6)
7	S	GR	BL-SB (C1-5)
8	L	BE	BL-LB (C1-4)
9	SY	GY	DM-SY (C1-1)

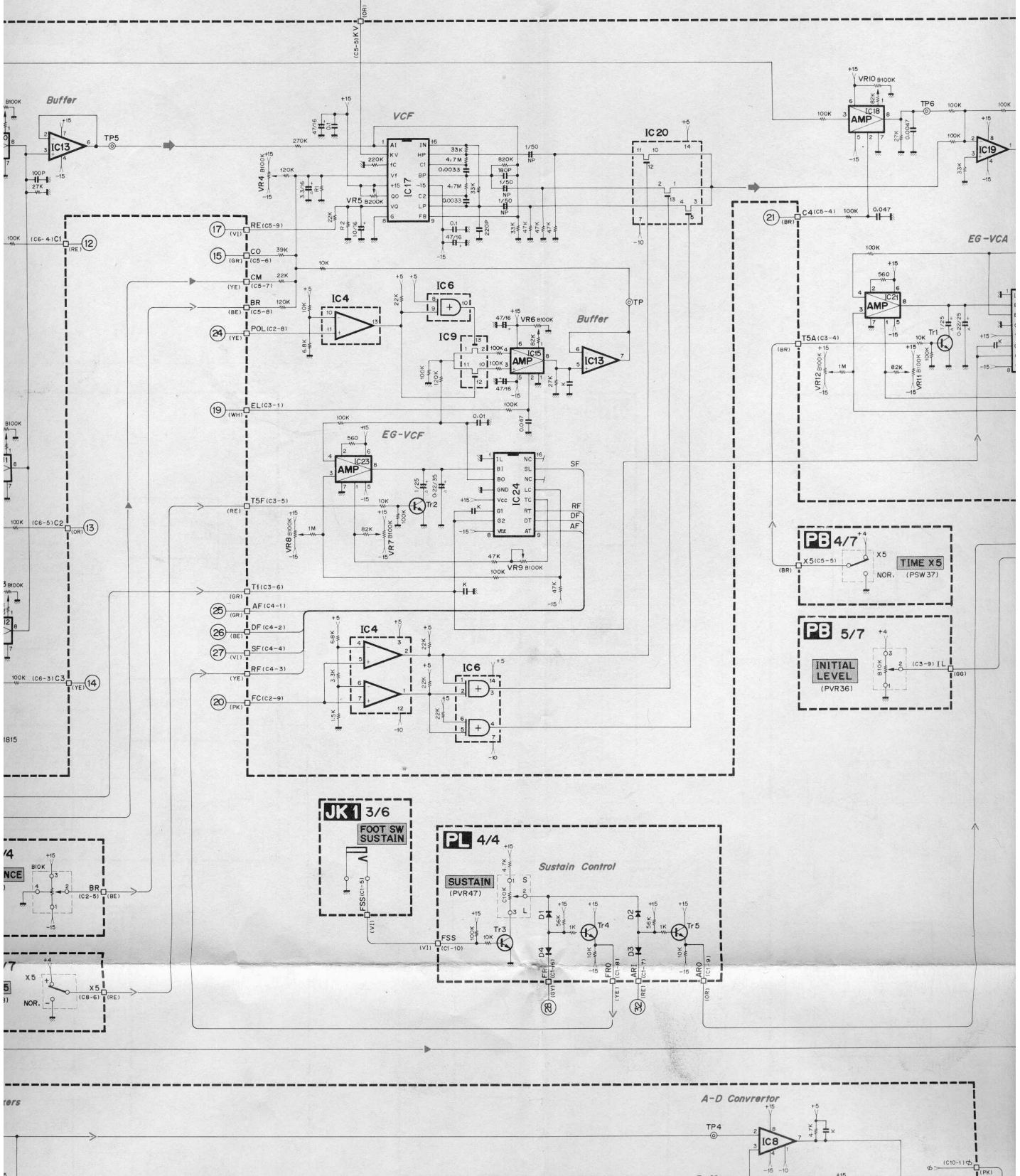

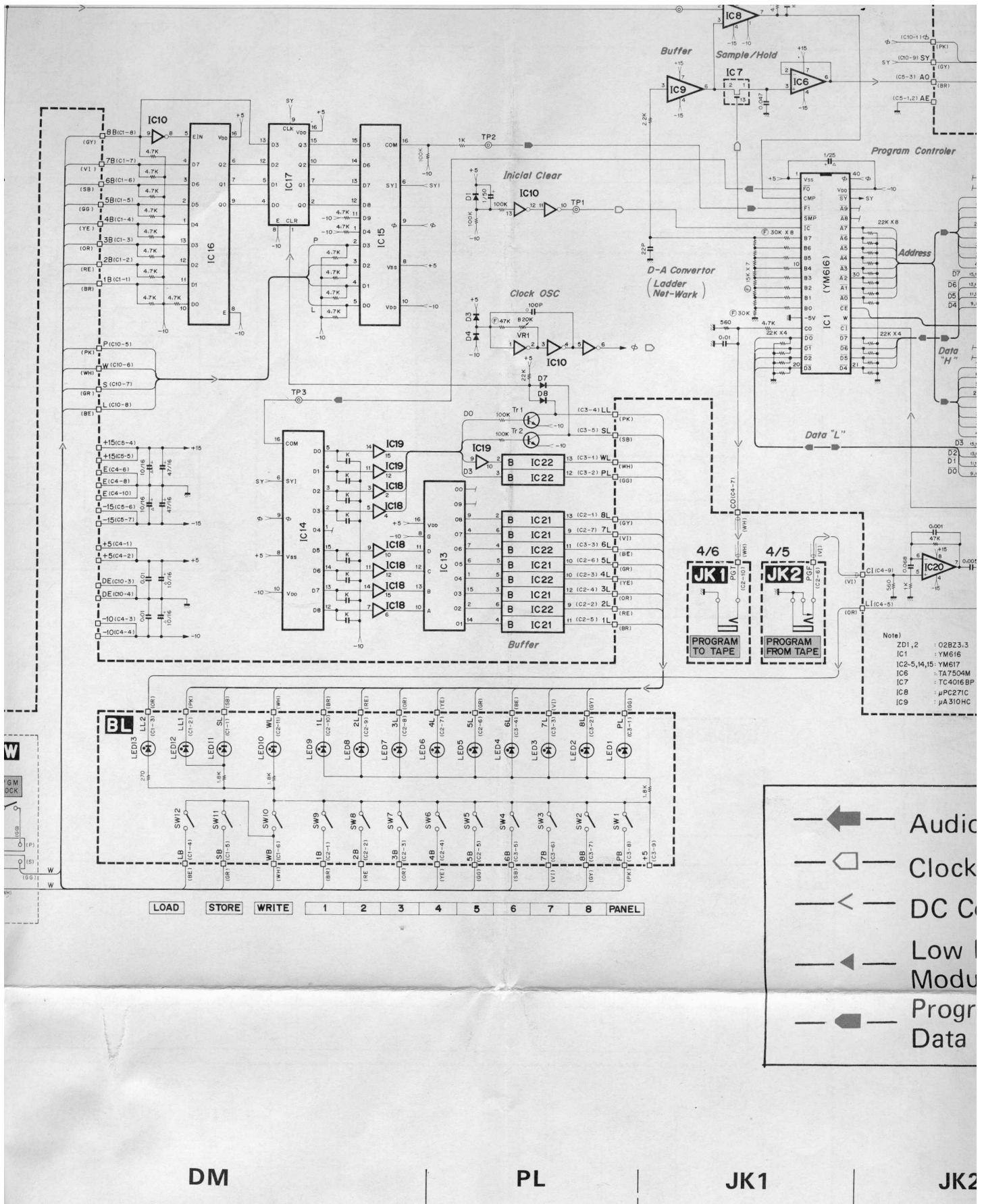

Note)  
 ZD1,2 : 02B23.3  
 IC1 : YM616  
 IC2-5,14,15 : YM617  
 IC6 : TA7504M  
 IC7 : TC4016BP  
 IC8 : µPC271C  
 IC9 : µA310HC

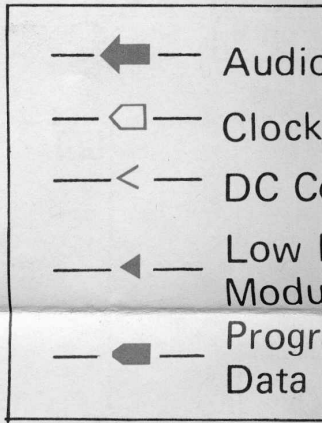

LOAD STORE WRITE 1 2 3 4 5 6 7 8 PANEL

# DM

## C1

Pin No.	Pin Name	Wire Color	Destination
1	SY	GY	PGM-SY (C10-9)
2	+5	GR	PGM+5 (C4-2)
3	+5	GR	BL+5 (C3-9)
4	∅	PK	PGM-∅ (C10-1)
5	-10	BE	PGM-10 (C4-4)

## C2

Pin No.	Pin Name	Wire Color	Destination
1	AI	BR	PGM-AO (C5-3)
2	+15	BR	PBM+15 (C5-5)
3	E	BL	PGM-AE (C5-2)
4	-15	YE	PGM-15 (C5-7)
5	31	BR	FA-SA (C4-8)
6	30	PK	FA-DA (C4-6)
7	29	WH	FA-AA (C4-5)

## C3

Pin No.	Pin Name	Wire Color	Destination
1	28	GY	PL-FPI (C1-6)
2	27	VI	FA-SF (C4-4)
3	26	BE	FA-DF (C4-2)
4	25	GR	FA-AF (C4-1)
5	24	YE	FA-POL (C2-8)
6	23	OR	MOD-AD (C3-5)
7	22	RE	MOD-MA (C1-4)
8	21	BR	FA-C4 (C5-4)
9	20	PK	FA-FC (C2-9)
10	19	WH	FA-EL (C3-1)

## C4

Pin No.	Pin Name	Wire Color	Destination
1	18	GY	MOD-FD (C3-6)
2	17	VI	FA-RE (C5-9)
3	16	BE	MOD-MF (C1-3)
4	15	GR	FA-C0 (C5-6)
5	14	YE	FA-C3 (C6-3)
6	13	OR	FA-C2 (C6-5)
7	12	RE	FA-C1 (C6-4)
8	11	BR	MOD-P2 (C4-3)
9	10	PK	FA-HB2 (C2-6)

## C5

Pin No.	Pin Name	Wire Color	Destination
1	9	WH	MOD-MD2 (C2-9)
2	8	GY	PB-FT2 (C1-7)
3	7	VI	MOD-MF2 (C1-2)
4	6	BE	MOD-P1 (C4-6)
5	5	GR	FA-HB1 (C2-7)
6	4	YE	MOD-MD1 (C3-2)
7	3	OR	PB-FT1 (C1-6)
8	2	RE	MOD-MF1 (C1-1)
9	1	BR	PA-S (C6-1)
10	32	RE	PL-ARI (C1-7)

# PL

## C1

Pin No.	Pin Name	Wire Color	Destination
1	POR	BE	SK-PS (C4-6)
2	FSP	GR	JK2-FSP (C1-3)
3	-10	BE	SK-10 (C3-6)
4	+5	GR	SK+5 (C3-8)
5	PG	BR	SK-PG (C4-5)
6	FRI	GY	DM-28 (C3-1)
7	ARI	RE	DM-32 (C5-10)
8	FRO	YE	FA-RF (C4-3)
9	ARO	OR	FA-RA (C4-7)
10	FSS	VI	JK1-FSS (C1-5)

## C2

Pin No.	Pin Name	Wire Color	Destination
1	VR	RE	SK-VR (C4-4)
2	-15	YE	DC-15 (C4-6)
3	E	BL	DC-AE (C3-3)
4	+15	BR	DC+15 (C4-2)
5	BR	BE	FA-BR (C5-8)
6	EK	BL	SK-EK (C4-2)
7	MO	WH	MOD-MW (C3-1)
8	MF	PK	MOD-FW (C3-7)

## C3

Pin No.	Pin Name	Wire Color	Destination
1	M3	RE	W1-3
2	M1	BL	W1-1
3	M3	BR	W1-2

## C4

Pin No.	Pin Name	Wire Color	Destination
1	PP	BR	W2-1
2	PN	OR	W2-3
3	PO	RE	W2-2
4	PE	BL	W2-4

# JK1

## C1

Pin No.	Pin Name	Wire Color	Destination
1	HO	SBE	PB-HO (C4-3)
2	E	SBES	
3	E	BL	DC-DE (C2-9)
4	E	BL	PB-E (C4-7)
5	FSS	VI	PL-FSS (C1-10)
6	FC	OR	PB-FC (C3-11)
7	-15'	YE	PB-15' (C2-8)

## C2

Pin No.	Pin Name	Wire Color	Destination
1	KV	SRE	PA-KV (C2-5)
2	KV	OR	FA-KV (C5-5)
3	KVF	YE	JK2-KV (C2-2)
4	EK	BL	DC-AE (C4-4)
5	EK	BL	JK2-KE (C2-3)
6	TR	SB	PA-TR (C7-5)
7	TRF	BE	SK-TR (C4-3)
8	E	BL	DC-DE (C1-9)
9	E	BL	JK2-E (C1-4)
10	PGT	SWH	PGM-CO (C4-7)

# JK2

## C1

Pin No.	Pin Name	Wire Color	Destination
1	LO	SVI	PB-L
2	E	SVIS	
3	FSP	GR	PL-F
4	E	BL	JK1

## C2

Pin No.	Pin Name	Wire Color	Destination
1	KV	OR	SK-
2	KV	YE	JK1
3	EK	BL	JK1
4	EK	BL	PA
5	TR	BE	PA
6	PGF	SVI	PG



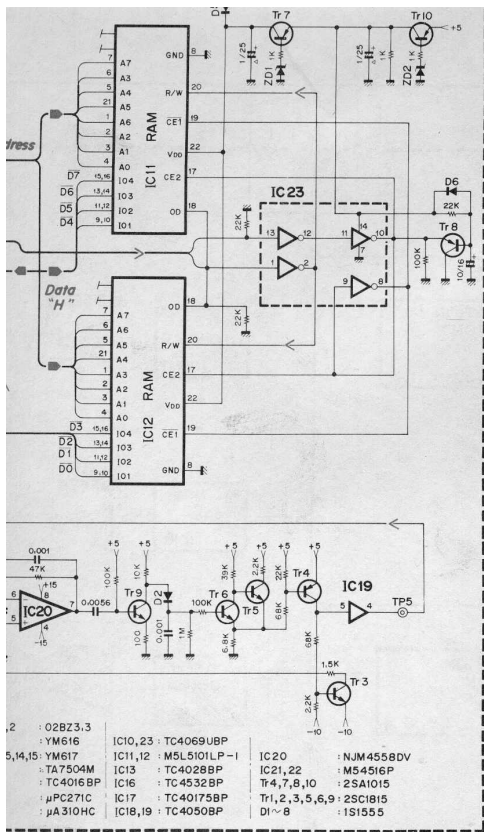

IC11,12 : M51501LP-1  
 IC21,22 : M54516P  
 Tr4,7,8,10 : 2SA1015  
 Tr1,2,3,5,6,9 : 2SC1815  
 D1~8 : 1S1555

Audio Signal  
 Clock Pulse  
 DC Control  
 Low Frequency  
 Modulation Data  
 Program Control  
 Data

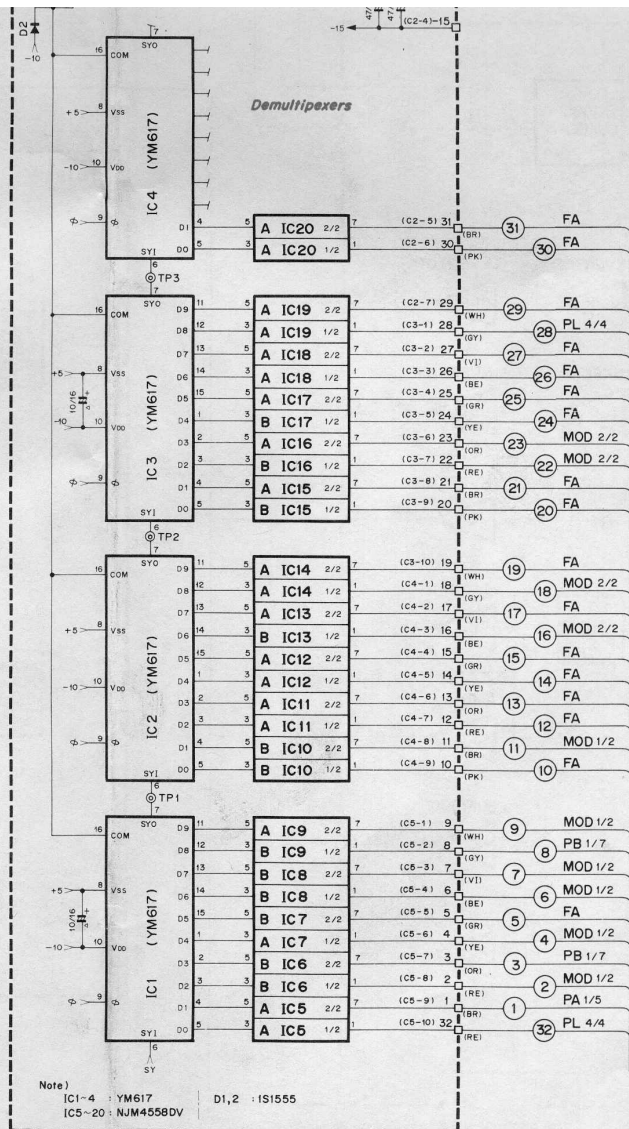

Note)  
 IC1-4 : YM617  
 IC5-20 : NJM4558DV  
 D1,2 : 1S1555

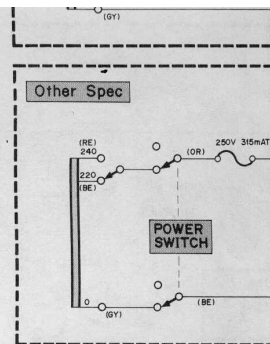

NO	BLOCK	FUNCTION
1	LFO	SPEED
2	VCO 1	MOD.FUNC
3	-do-	FEET
4	-do-	MOD.DEPTH
5	-do-	WAVE
6	-do-	PW
7	VCO 2	MOD.FUNC
8	-do-	FEET
9	-do-	MOD.DEPTH
10	-do-	WAVE
11	-do-	PW
12	MIXER	VCO 1
13	-do-	VCO 2
14	-do-	NOISE
15	VCF	CUT OFF FREQ.
16	-do-	MOD.FUNC
17	-do-	RESONANCE
18	-do-	MOD.DEPTH
19	-do-	EG DEPTH
20	-do-	HP/BP/LP
21	VCA	~1
22	-do-	MOD.FUNC
23	-do-	DEPTH
24	EG-VCF	EG/POLE
25	-do-	ATTACK TIME
26	-do-	DECAY TIME
27	-do-	SUSTAIN LEVEL
28	-do-	RELEASE TIME
29	EG-VCA	ATTACK TIME
30	-do-	DECAY TIME
31	-do-	SUSTAIN LEVEL
32	-do-	RELEASE TIME

To the same terminal No indicated on each circuit

JK2

MK

BL

DC

## JK2

### C1

Wire Color	Destination
SVI	PB-LO (C4-6)
SVIS	
GR	PL-RSP (C1-2)
BL	JK1-E (C2-9)

### C2

Wire Color	Destination
OR	SK-KV (C3-1)
YE	JK1-KVF (C2-3)
BL	JK1-EK (C2-5)
BE	PA-EK (C2-7)
BE	PA-LT (C7-2)
SVI	PGM-CI (C4-9)

## MK

### C1

Pin No.	Pin Name	Wire Color	Destination
1	B1	BR	SK-B1 (C1-6)
2	B2	RE	SK-B2 (C1-5)
3	B3	OR	SK-B3 (C1-4)
4	B4	YE	SK-B4 (C1-3)
5	B5	GR	SK-B5 (C1-2)
6	B6	BE	SK-B6 (C1-1)
7	CL	BL	SK-NO (C2-7)
8	C	VI	SK-N1 (C2-6)

### C2

Pin No.	Pin Name	Wire Color	Destination
1	D	GY	SK-N2 (C2-5)
2	D	WH	SK-N3 (C2-4)
3	E	GG	SK-N4 (C2-3)
4	F	SB	SK-N5 (C2-2)
5	F	PK	SK-N6 (C2-1)

## BL

### C1

Pin No.	Pin Name	Wire Color	Destination
1	SL	SB	PGM-SL (C3-5)
2	LL1	PK	PGM-LL (C3-4)
3	LL2	OR	PGM-LI (C4-5)
4	LB	BE	PGM-L (C10-8)
5	SB	GR	PGM-S (C10-7)
6	WB	WH	PGM-W (C10-6)

### C2

Pin No.	Pin Name	Wire Color	Destination
1	1B	BR	PGM-1B (C1-1)
2	2B	RE	PGM-2B (C1-2)
3	3B	OR	PGM-3B (C1-3)
4	4B	YE	PGM-4B (C1-4)
5	5B	GG	PGM-5B (C1-5)
6	5L	GR	PGM-5L (C2-6)
7	4L	YE	PGM-4L (C2-3)
8	3L	OR	PGM-3L (C2-4)
9	2L	RE	PGM-2L (C2-2)
10	1L	BR	PGM-1L (C2-5)
11	WL	WH	PGM-WL (C3-1)

### C3

Pin No.	Pin Name	Wire Color	Destination
1	PL	GG	PGM-PL (C3-2)
2	8L	GY	PGM-8L (C2-1)
3	7L	VI	PGM-7L (C2-7)
4	6L	BE	PGM-6L (C3-3)
5	6B	SB	PGM-6B (C1-6)
6	7B	VI	PGM-7B (C1-7)
7	8B	GY	PGM-8B (C1-8)
8	PB	PK	PGM-P (C10-5)
9	+5	GR	DM-+5 (C1-3)

## DC

### C1

Pin No.	Pin Name	Wire Color	Destination
1	+15	BR	PA-+15 (C6-7)
2	+15	BR	PB-+15 (C3-3)
3	AE	BL	PA-E (C6-6)
4	AE	BL	PB-E (C3-2)
5	-15	YE	PA- -15 (C6-5)
6	-15	YE	PB- -15 (C3-1)
7	+5	GR	PB-+5 (C1-4)
8	DE	BL	PB-E (C1-3)
9	DE	BL	JK1-E (C2-8)
10	-10	BE	PB- -10 (C1-1)

### C2

Pin No.	Pin Name	Wire Color	Destination
1	+15	BR	PGM-+15 (C5-4)
2	+15	BR	FA-+15 (C1-9)
3	AE	BL	PGM-AE (C5-1)
4	AE	-	-
5	-15	YE	PGM- -15 (C5-6)
6	-15	YE	FA- -15 (C1-5)
7	+5	GR	PGM-+5 (C4-1)
8	DE	BL	PGM-DE (C10-3)
9	DE	BL	JK1-DE (C1-3)
10	-10	BE	PGM- -10 (C4-3)

### C3

Pin No.	Pin Name	Wire Color	Destination
1	+15	BR	PA-+15 (C4-1)
2	+15	BR	VCO-+15 (C1-8)
3	AE	BL	PL-E (C2-3)
4	AE	BL	VCO-E (C1-6)
5	-15	YE	PA- -15 (C4-4)
6	-15	YE	VCO- -15 (C1-3)
7	+5	GR	MOD-+5 (C1-7)
8	DE	BL	PGM-E (C4-10)
9	DE	BL	FA-E (C1-7)
10	-10	BE	MOD- -10 (C1-5)

### C4

Pin No.	Pin Name	Wire Color	Destination
1	+15	BR	SK-+15 (C3-2)
2	+15	BR	PL-+15 (C2-4)
3	AE	BL	SK-EK (C4-1)
4	AE	BL	JK1-EK (C2-4)
5	-15	YE	SK- -15 (C3-3)
6	-15	YE	PL- -15 (C2-2)
7	+5	GR	SK-+5 (C3-7)
8	DE	BL	SK-DE (C3-4)
9	DE	-	-
10	-10	BE	SK- -10 (C3-6)

## HP

Pin No.	Pin Name	Wire Color	Destination
1	HR	RE	PB-HR (C4-1)
2	HL	OR	PB-HL (C4-2)
3	E	GR	MK-SE

## XLR

Pin No.	Pin Name	Wire Color	Destination
1	-	-	-
2	RE	-	PB-O+ (C4-10)
3	WH	-	PB-O- (C4-9)

## BB

Pin No.	Pin Name	Wire Color	Destination
	E	BLX2	PGM-DE (C10-4) BC-2 (C1-2)
	VB	ORX2	PGM-VB (C10-2) BC-1 (C1-1)

## BC

Pin No.	Pin Name	Wire Color	Destination
1	1	OR	BB-VB
2	2	BL	BB-E

## W1

Pin No.	Pin Name	Wire Color	Destination
1	1	BL	PL-M1 (C3-2)
2	2	BR	PL-M2 (C3-3)
3	3	RE	PL-M3 (C3-1)

## W2

Pin No.	Pin Name	Wire Color	Destination
1	1	BR	PL-PP (C4-1)
2	2	RE	PL-PO (C4-3)
3	3	OR	PL-PN (C4-2)
4	4	BL	PL-PE (C4-4)

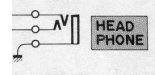
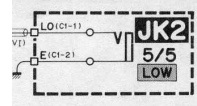
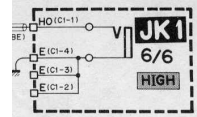
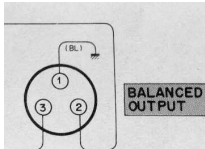

Canadian Spec.

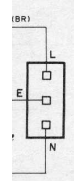

- : NJM4558
- : 25D235
- : 25C2120
- : 25C1815
- : 25A1015
- : 25A950
- : 25A490
- 7: 1D2C1
- 8: 1D2Z1
- : 1S1555
- : RD15EB3
- : RD5.6EB3
- : RD3.6EB1

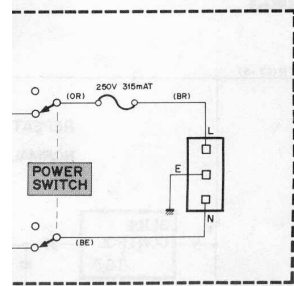
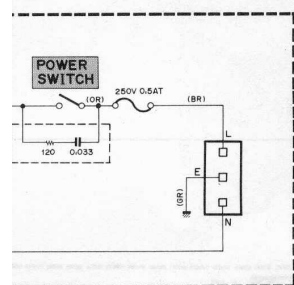

## PL Circuit Board

### 1. Key Volt Generator

EFFECT Block PITCH (PSW48)	Test Point	Specification	Adjustment
OCTAVE	Terminal PP	$-2 \pm 0.001$	VR1
FIFTH	Terminal PP	$-0.997 \pm 0.003$	
THIRD	Terminal PP	$-0.520 \pm 0.003$	
OCTAVE	Terminal PN	$+1 \pm 0.001$	VR2
FIFTH	Terminal PN	$+0.665 \pm 0.003$	
THIRD	Terminal PN	$+0.413 \pm 0.003$	

EFFECT Block PITCH BEND (PVR49)	Test Point	Specification	Adjustment
0 (Terminal PO 0V)	Terminal VR	$+2 \pm 0.001$	VR3
+ ▲ (Terminal PO $-2 \pm 0.001$ V)	Terminal VR	$+4 \pm 0.005$	

↑  
Set the PITCH switch (PSW48) to OCTAVE.

### 2. Modulation Buffer

EFFECT Block MODULATION (PSW50)	Test Point	Specification [Note 1] [V]	Specification [Note 2] [V]
VCO	Terminal MO Terminal MF	$+10.4 \pm 0.5$ 0	$+0.61 \pm 0.05$ 0
VCO + VCF	Terminal MO Terminal MF	$+10.4 \pm 0.5$ $+10.4 \pm 0.5$	$+0.61 \pm 0.05$ $+0.61 \pm 0.05$
VCF	Terminal MO Terminal MF	0 $+10.4 \pm 0.5$	0 $+0.61 \pm 0.05$

Note 1: The Modulation wheel (PVR51) is turned fully upward.

Note 2: The Modulation wheel (PVR51) is turned fully downward.

### 3. Portamento Control

Connect the foot switch to the PORTAMENT FOOT SW jack.

Set PORTAMENTO (PRV45) to "L".

When the foot switch is released off, a  $-10 \pm 0.1$  volts should be obtained at terminal POR.

When the foot switch is pressed on, a  $+5 \pm 0.1$  volts should be obtained at terminal POR.

When the PORTAMENTO/GLISSAND switch (PSW44) is set to GLISSAND, a  $+5 \pm 0.1$ VDC should be obtained at terminal PG.

### 4. Sustain Control

Connect the foot switch to the SUSTAIN FOOT SW jack.

Set the RELEASE TIME switch for EG-VCF and EG-VCA to "S". (Terminals FRI and ARI: +10V)

Set the SUSTAIN switch (PVR47) to "S".

When the foot switch is released off, a  $+10 \pm 1$ VDC should be obtained at terminals FRO and ARO.

When the SUSTAIN switch is set to "L", a  $0 \pm 1$ VDC should be obtained at terminals FRO and ARO.

When the foot switch is pressed on, a  $+10 \pm 1$ VDC should be obtained at terminals FRO and ARO.







### 5. Brilliance Control

When the BRILLIANCE switch (PVR46) is set to "+" position, a  $+15 \pm 0.1$ VDC should be obtained at terminal BR.

When the BRILLIANCE switch is set to the "-" position, a  $-15 \pm 0.1$ VDC should be obtained at terminal BR.

### Parameter Control Voltage List

Circuit Board	Block	Function	Position	Voltage [V]	Remarks
PA	VCO1, 2	FEET	64'	0	Measure the voltage across terminals FV1 (C3-3) and FV2 (C5-2).  ± 10%
			32'	0.67	
			16'	1.33	
			8'	2.00	
			4'	2.67	
			2'	3.33	
	WAVE	∧	0	Terminal WV1 (C3-6)	
		∟	1.33	Terminal WV2 (C5-5)	
		∟	2.67	± 10%	
	MODULATION FUNCTION	∩	0	Terminal MF1 (C3-1)	
		∟	0.57	Terminal MF2 (C4-7)	
∨		1.14			
∟		1.71			
S/H		2.29			
G <sup>+</sup>		2.86			
G <sup>-</sup>		3.43	± 10%		
MODULATION DEPTH	0 ~ 10	0 ~ 4	Terminal MD1 (C3-2) Terminal MD2 (C5-1)		
PW (PULSE WIDTH)	50 ~ 90	0 ~ 4	Terminal P1 (C3-5) Terminal P2 (C5-4)		
LFO	SPEED	S ~ F	0 ~ 4	Terminal LS (C6-1)	
PB	MIXER	VCO1	0 ~ 10	0 ~ 4	Terminal VO1 (C2-3)
		VCO2	0 ~ 10	0 ~ 4	Terminal VO2 (C2-1)
		NOISE	0 ~ 10	0 ~ 4	Terminal WN (C8-1)
	VCF	CUT OFF FREQ.	L ~ H	0 ~ 4	Terminal (C2-4)
		RESONANCE	L ~ H	0 ~ 4	Terminal RE (C2-5)
		FILTER MODE	LP	0	Terminal FM (C3-5)
			BP	1.33	
	HP		2.67	± 10%	
	MODULATION FUNCTION	∩	0	Terminal MF (C3-6)	
		∟	0.8		
∨		1.6			
∟		2.4			
S/H		3.2	± 10%		

Circuit Board	Block	Function	Position	Voltage [V]	Remarks		
PB	VCF	MODULATION DEPTH	0 ~ 10	0 ~ 4	Terminal MD (C3-8)		
		EG DEPTH	0 ~ 10	0 ~ 4	Terminal ED (C2-7)		
	EG-VCF	POLARITY	 		4 0	Terminal PL (C8-7)	
		TIME EXPAND	NORMAL TIME X5		0 4	Terminal X5 (C8-6)	
		ATTACK TIME	S ~ L		4 ~ 0	Terminal FA (C8-2)	
		DECAY TIME	S ~ L		4 ~ 0	Terminal FD (C8-3)	
		SUSTAIN LEVEL	0 ~ 10		0 ~ 3.4 ± 0.4	Terminal FS (C8-4)	
		RELEASE TIME	S ~ L		4 ~ 0	Terminal FR (C8-5)	
		VCA	~ 1		0 ~ 10	0 ~ 4	Terminal 1 (C3-7)
	MODULATION FUNCTION		   		0 1 2 3	Terminal MF (C3-6)   ± 10%	
	MODULATION DEPTH		0 ~ 10		0 ~ 4	Terminal MD (C3-8)	
	INITIAL LEVEL		0 ~ 10		0 ~ 4	Terminal IL (C3-9)	
	EG-VCA		TIME EXPAND	NORMAL TIME X5		0 4	Terminal X5 (C5-5)
			ATTACK TIME	S ~ L		4 ~ 0	Terminal AA (C5-1)
		DECAY TIME	S ~ L		4 ~ 0	Terminal AD (C5-2)	
		SUSTAIN LEVEL	0 ~ 10		0 ~ 3.4 ± 0.4	Terminal AS (C5-3)	
		RELEASE TIME	S ~ L		4 ~ 0	Terminal AR (C5-4)	

A

B

C

D

1

2

3

4

5

6

KEYBOARD(C3-C6)

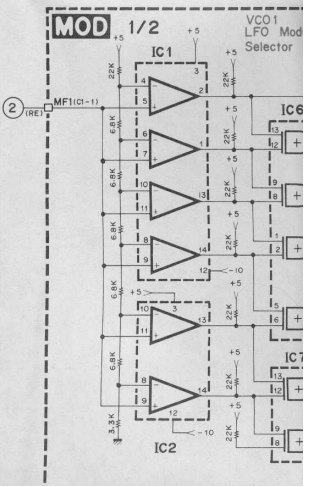
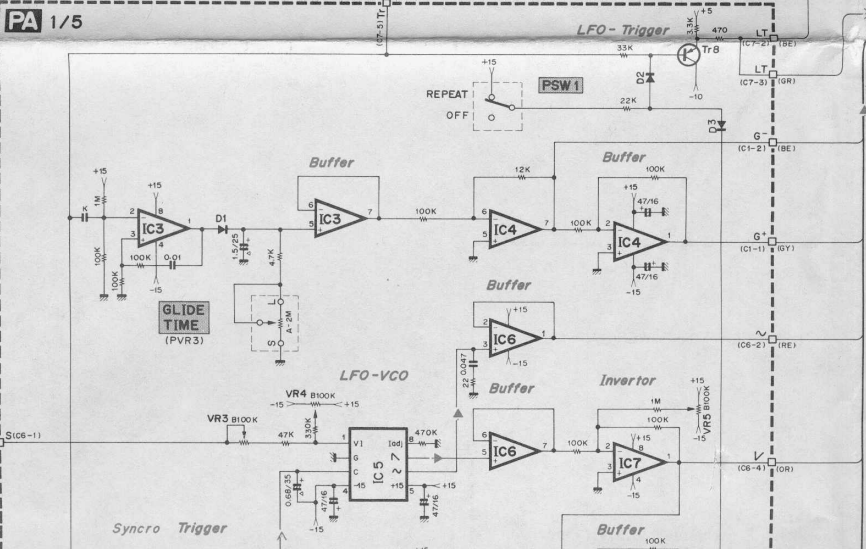
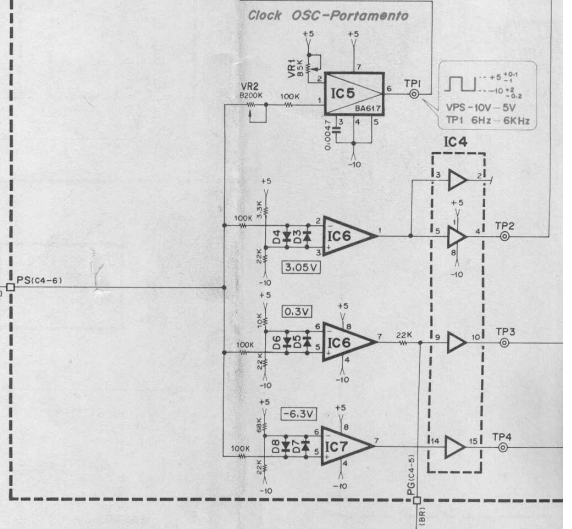
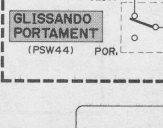
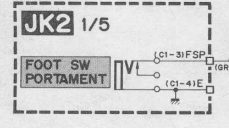
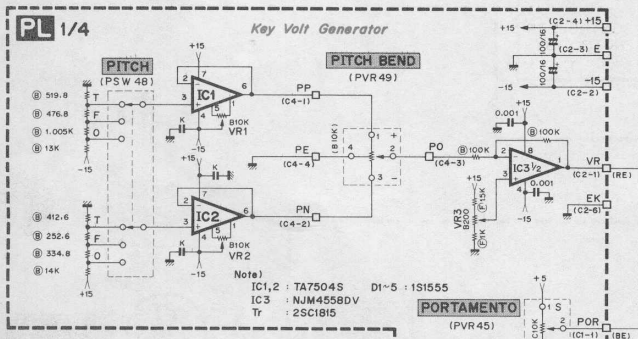
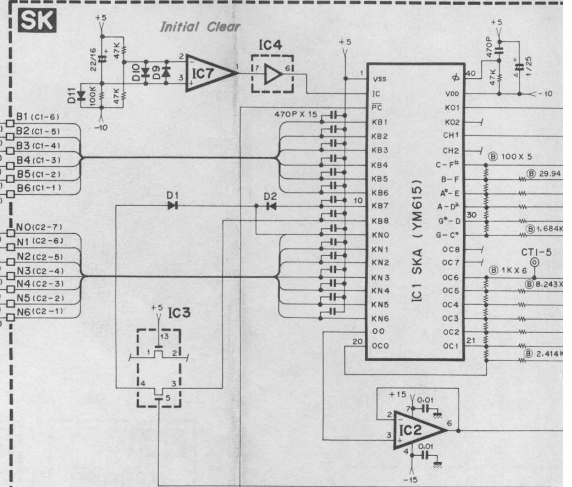
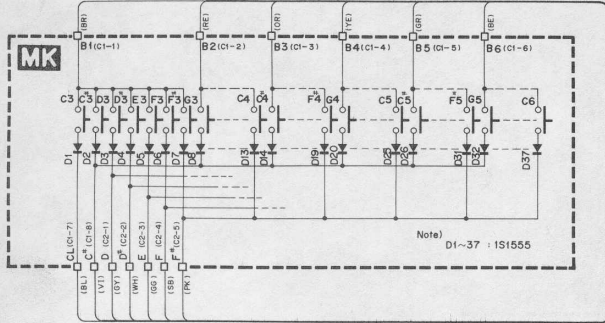
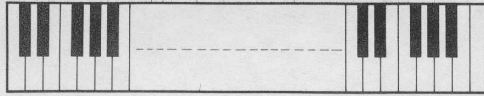

7

8

9

10

11

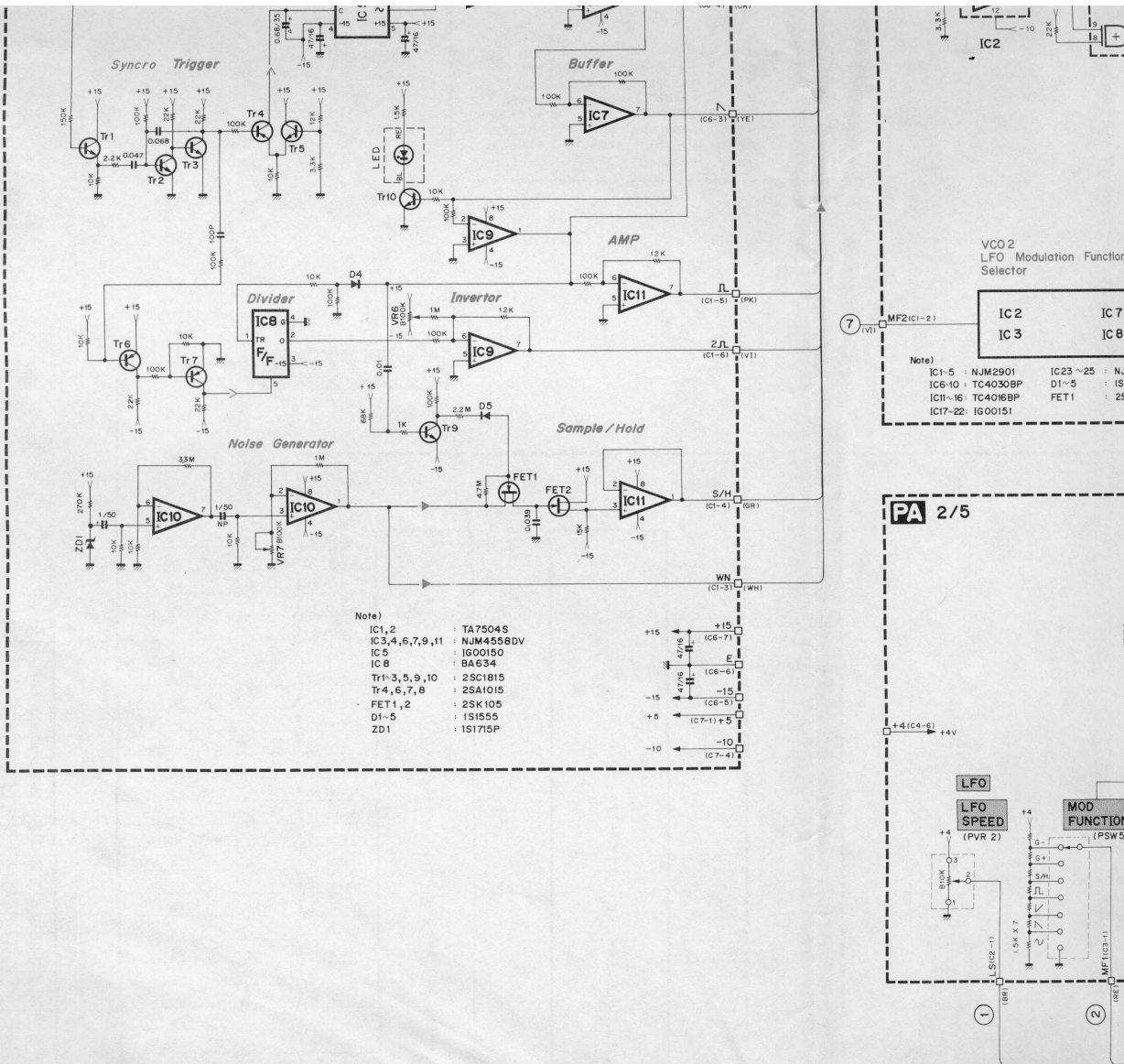

SK

C1

Pin No.	Pin Name	Wire Color	Destination
1	B6	BE	MK-B6 (C1-6)
2	B5	GR	MK-B5 (C1-5)
3	B4	YE	MK-B4 (C1-4)

PA

C1

Pin No.	Pin Name	Wire Color	Destination
1	G+	GY	MOD-G+ (C2-8)
2	G-	BE	MOD-G- (C2-6)
3	WN	SWH	FA-NI (C6-1)

C5

Pin No.	Pin Name	Wire Color	Destination
1	MD2	WH	PGM-9 (C6-4)
2	FV2	GY	PGM-8 (C6-3)
3	PD2	RE	MOD-PD2 (C3-4)

C1

Pin No.	Pin Name	Wire Color	Destination
1	-10	BE	DC-10 (C1-10)
2	-10	BE	PA-10 (C7-4)
3	E	BL	DC-DE (C1-8)

11

## SK

## C1

Pin No.	Pin Name	Wire Color	Destination
1	B6	BE	MK-B6 (C1-6)
2	B5	GR	MK-B5 (C1-5)
3	B4	YE	MK-B4 (C1-4)
4	B3	OR	MK-B3 (C1-3)
5	B2	RE	MK-B2 (C1-2)
6	B1	BR	MK-B1 (C1-1)

## C2

Pin No.	Pin Name	Wire Color	Destination
1	N6	PK	MK-F# (C2-5)
2	N5	SB	MK-F (C2-4)
3	N4	GG	MK-E (C2-3)
4	N3	WH	MK-D# (C2-2)
5	N2	GY	MK-D (C2-1)
6	N1	VI	MK-C# (C1-8)
7	N0	BL	MK-CL (C1-7)

## C3

Pin No.	Pin Name	Wire Color	Destination
1	KV	OR	JK2-KV (C2-1)
2	+15	BR	DC-+15 (C4-1)
3	-15	BR	DC- -15 (C4-5)
4	DE	BL	DC-DE (C4-8)
5	-10	BE	DC- -10 (C4-10)
6	-10	BE	PL- -10 (C1-3)
7	+5	GR	DC-+5 (C4-7)
8	+5	GR	PL-+5 (C1-4)

## C4

Pin No.	Pin Name	Wire Color	Destination
1	EK	BL	DC-AE (C4-3)
2	EK	BL	PL-EK (C2-6)
3	TR	BE	JK1-TRF (C2-7)
4	VR	RE	PL-VR (C2-1)
5	PG	BR	PL-PG (C1-5)
6	PS	BR	PL-POR (C1-1)

## PA

## C1

Pin No.	Pin Name	Wire Color	Destination
1	G <sup>+</sup>	GY	MOD-G <sup>+</sup> (C2-8)
2	G <sup>-</sup>	BE	MOD-G <sup>-</sup> (C2-6)
3	WN	SWH	FA-NI (C6-1)
4	S/H	GR	MOD-S/H (C2-5)
5	FL	WH	MOD-FL (C2-3)
6	2 FL	VI	MOD-2 FL (C2-7)

## C2

Pin No.	Pin Name	Wire Color	Destination
1	LS	BR	PGM-1 (C6-10)
2	+15	BR	PA-+15 (C4-2)
3	CV1	SOR	VCO-KV (C2-2)
4	-15	YE	PA- -15 (C4-5)
5	KV	SRE	JK1-KV (C2-1)
6	EK	SRES	
7	EK	BL	JK2-EK (C2-4)
8	EK	BL	VCO-EK (C1-1)

## C3

Pin No.	Pin Name	Wire Color	Destination
1	MF1	RE	PGM-2 (C6-9)
2	MD1	YE	PGM-4 (C6-7)
3	FV1	OR	PGM-3 (C6-8)
4	PD1	BR	MOD-PD1 (C3-3)
5	P1	BE	PGM-6 (C6-1)
6	WV1	GR	PGM-5 (C6-6)

## C4

Pin No.	Pin Name	Wire Color	Destination
1	+15	BR	DC-+15 (C3-1)
2	+15	BR	PA-+15 (C2-2)
3	CV2	RE	VCO-KV (C1-2)
4	-15	YE	DC- -15 (C3-5)
5	-15	YE	PA- -15 (C2-4)
6	+4	VI	PB-+4 (C3-4)
7	MF2	VI	PGM-7 (C6-2)

## C5

Pin No.	Pin Name	Wire Color	Destination
1	MD2	WH	PGM-9 (C6-4)
2	FV2	GY	PGM-8 (C6-3)
3	PD2	RE	MOD-PD2 (C3-4)
4	P2	BR	PGM-11 (C8-1)
5	WV2	PK	PGM-10 (C6-5)

## C6

Pin No.	Pin Name	Wire Color	Destination
1	S	BR	DM-1 (C5-9)
2	~	RE	MOD-~ (C2-1)
3	∩	YE	MOD-∩ (C2-4)
4	∨	OR	MOD-∨ (C2-2)
5	-15	YE	DC- -15 (C1-5)
6	E	BL	DC-AE (C1-3)
7	+15	BR	DC-+15 (C1-1)

## C7

Pin No.	Pin Name	Wire Color	Destination
1	+5	GR	PB-+5 (C1-5)
2	LT	BE	JK2-TR (C2-5)
3	LT	GR	FA-T1 (C3-6)
4	-10	BE	PB- -10 (C1-2)
5	TR	SB	JK1-TR (C2-6)

## C1

Pin No.	Pin Name	Wire Color	Destination
1	-10	BE	DC- -10 (C1-10)
2	-10	BE	PA- -10 (C7-4)
3	E	BL	DC-DE (C1-8)
4	+5	GR	DC-+5 (C1-7)
5	+5	GR	PA-+5 (C7-1)
6	FT1	OR	DM-3 (C5-7)
7	FT2	GY	DM-8 (C5-2)

## C2

Pin No.	Pin Name	Wire Color	Destination
1	VO2	OR	PGM-13 (C7-8)
2	MF	BE	PGM-16 (C7-5)
3	VO1	RE	PGM-12 (C7-9)
4	CO	GR	PGM-15 (C7-6)
5	RE	VI	PGM-17 (C7-4)
6	MD	GY	PGM-18 (C7-3)
7	ED	WH	PGM-19 (C7-2)
8	-15'	YE	JK1- -15' (C1-7)

## C3

Pin No.	Pin Name	Wire Color	Destination
1	-15	YE	DC- -15 (C1-6)
2	E	BL	DC-AE (C1-4)
3	+15	BR	DC-+15 (C1-2)
4	+4	VI	PA-+4 (C4-6)
5	FM	PK	PGM-20 (C7-1)
6	MF	RE	PGM-22 (C9-3)
7	1	BR	PGM-21 (C9-4)
8	MD	OR	PGM-23 (C9-2)
9	IL	GG	FA-IL (C3-2)
10	I	SRE	FA-O1 (C5-1)
11	FC	OR	JK1-PC (C1-6)

## C4

Pin No.	Pin Name	Wire Color	Destination
1	HR	RE	HP-HR
2	HL	OR	HP-HL
3	HO	SBE	JK1-HO (C1-1)
4	E	SBES	
5	E	SVIS	
6	LO	SVI	SK2-LO (C1-1)
7	E	BL	JK1-E (C1-4)
8	E	BL	FA-E (C5-3)
9	O <sup>-</sup>	RE	XLR-3
10	O <sup>+</sup>	WH	XLR-2

12

13

14